



Electronic Design & Research
<http://www.vsholding.com>

Technology for people's ideas

Input Specifications:

Input Voltage see the Features
 Nominal Current 5mA, 60Hz, 120VAC

Series D1A- I/O Solid State Relay

AC input, DC&DC/AC output Solid State Relays

Features: Utilizes only .65 sq. in. of PCB area and only .6" tall
 3 Amp continues or up to 5 Amp-pick in miniature size
 High sensitivity, even at a high switching frequency
 12 A surge current and only 70 mill-Ohms low on-state resistance
 Available in DIP24 and a miniature SIP4 packages
 Please specify input control voltage: control voltage

Typical Output Specifications (D1A60D3/120):

Output DC voltage range 0 - 60 VDC
 Maximum continuous current 3.3 A
 Peak Load Current - 100mS 12 A
 Continues current (ID) 5 A
 Maximum on-state resistance .070 Ohm
 Rising time 100 μS
 Delay-on time 275 μS
 Falling time 2.600 μS
 Delay-off time 17 μS
 Maximum switching frequency 40 Hz at 60Hz signal

* Test performed at the input current equal to 5 mA

General Specifications:

Ambient operating temperature range -25⁰ C to 85⁰ C
 Ambient storage temperature range -55⁰ C to 125⁰ C
 Dielectric Strength input-to-output 1,500 VAC

Mechanical Specifications:

Weight(oz) .1
 Encapsulation ResTech 10207/053
 Dimensions for D2L package 1.15"H x 1.75"L x 0.4"W
 Dimensions for DIP24 package 0.375"H x 0.925"L x 0.53"W
 Dimensions for D1L package 0.615"H x 1.485"L x 0.29"W
 Terminals/solder for DIP24 package 0.032" diameter
 Terminals/solder for SIP4m package 0.032" diameter

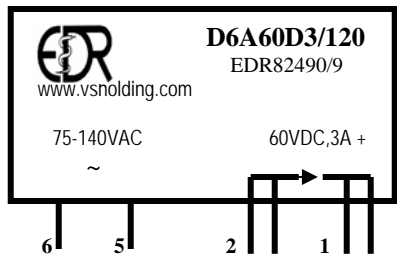
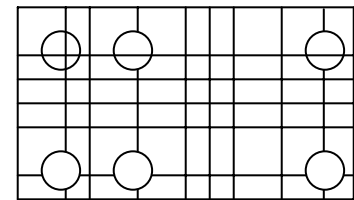
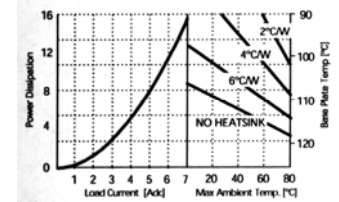
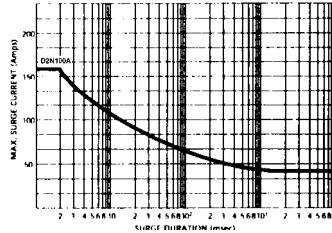

* replace "K" with a desired and offered control voltage

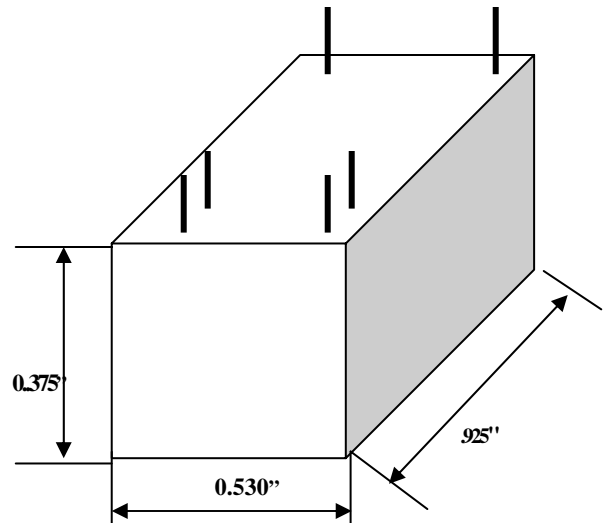

Transient Protection: All loads are inductive, even ones that are not so obvious or labeled. An inductive load produces a harmful transient voltage, which is much higher than the applied voltage, when it is turned on and off. A SSR built with a MOSFET output acts as an ideal switch and can produce a seemingly "non-inductive" load, which can cause damage if not suppressed. A transient voltage suppressor, which is bi-directional for an AC applied voltage and unidirectional for a DC applied voltage, should be used to clamp excessive spikes.

Electronic Design & Research Inc. ** 7331 Intermodal Dr. ** Louisville ** KY 40258

Tel: 502-933-8660; Fax: 502-933-3422; Sales: 800-336-1337; e-mail: vsholding@vsholding.com

Input Electrical Characteristics (Ta = 25°C) for xxx\120 model, DIP24 & SIP4

Characteristic	Test Condition, 60Hz	Min	Typ.	Max.	Unit
Voltage	continues	75	100	140	VAC
Current	continues	5.0	7.0	9.5	mA
Current (max)	10 sec			50	mA
Voltage (max)	10 sec			200	VAC

Input Electrical Characteristics (Ta = 25°C) for xxx\5 model, SIP4

Forward Voltage		3.8	4.3	7.5	V
Forward Current		10	15	30	mA
Reverse Current	Reverse Voltage = 3V			10	µA
Reverse voltage (max)				7	V

Input Electrical Characteristics (Ta = 25°C) for xxx\3.4-15 model, SIP4

Forward Voltage		3.4	9	15	V
Forward Current		10	20	23	mA
Reverse Current (max)	Reverse Voltage = 7V			10	µA
Reverse voltage (max)				20	V

Isolation and Temperature Characteristics for all models, DIP24 & SIP4

Capacitance input to output			0.8		pF
Isolation resistance	tested at 500V, R.H. [60%	5x10 ¹⁰	10 ¹⁴		Ω
Isolation voltage	AC, 1 minute	2500			Vrms
Storage Temperature			-55 ~ 125		°C
Operating temperature		-25		85	°C

Packaging information and pins-out for a mini SIP4m.

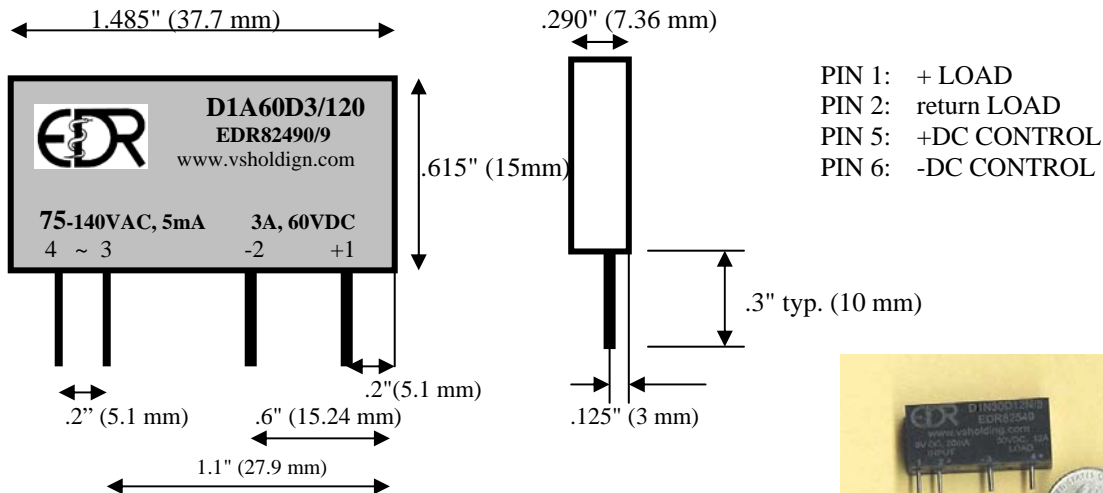

All Dimensions are in inches (millimeters).

Input terminals (pins) .040" (1 mm) diameter.

Output terminals (pins) .060"

Weight: (typical) .35 oz. (9.9 g)

Encapsulation: Thermally Conductive Epoxy

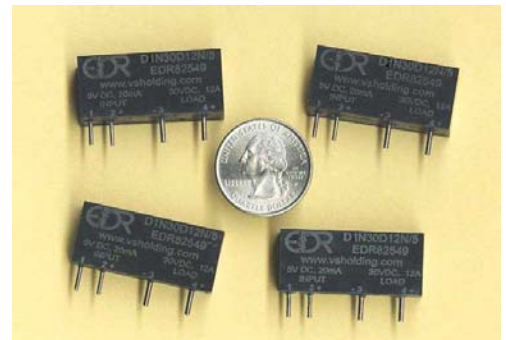

I. Switching time test – Load - 10VDC & 10A, Control Signal – 4.8 VDC & current 20 mA

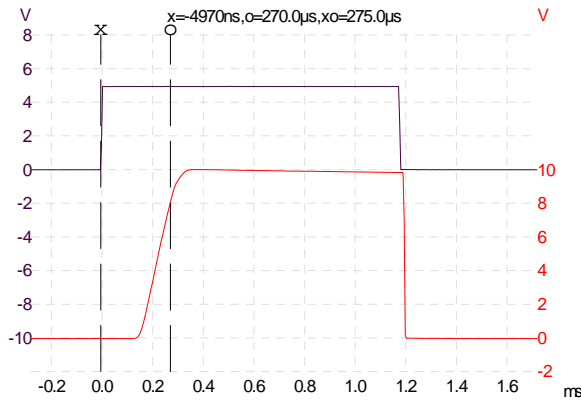

Figure 1. Turn-on delay is 275 µs

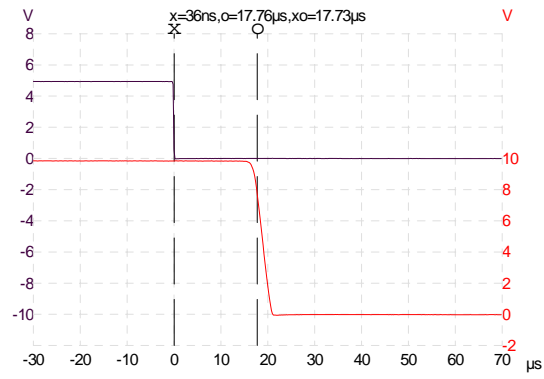

Figure 2. Turn-off delay is 17.73 µs

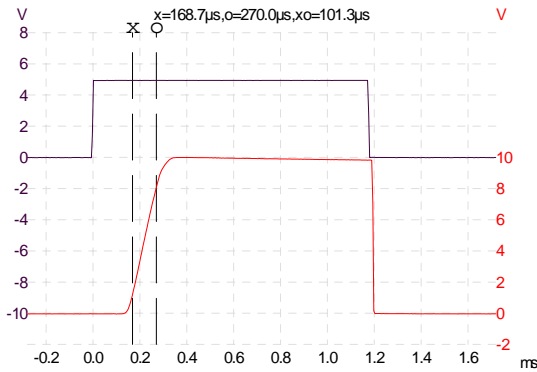

Figure 3. Rising Time is 101.3 µs

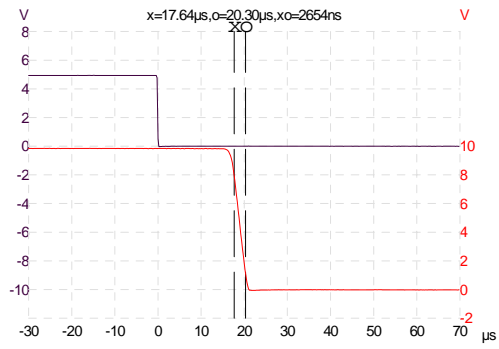

Figure 4. Fall Time is 2.654 µs

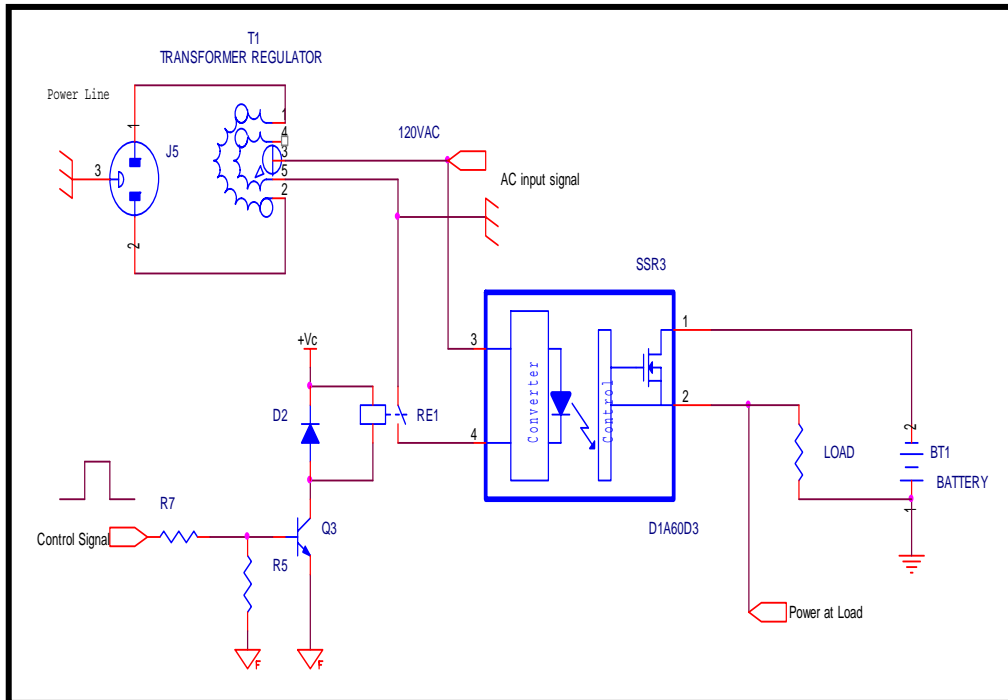
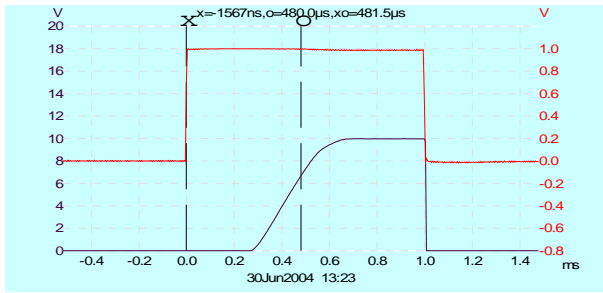

Figure 5. Switching Time Test Circuit

III. Switching time test vs. the control current – Load is 10VDC, 10A and the pulse duration is 1.0 ms

Control current is 10 mA or about 3.3 VDC



Turn-on delay is 481.5 μ S

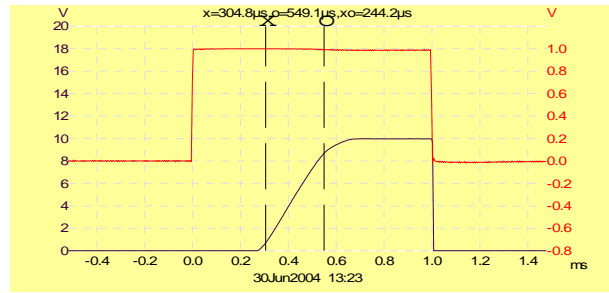

Rising time is 244.5 μ S

Control current is 20 mA or about 5.5 VDC

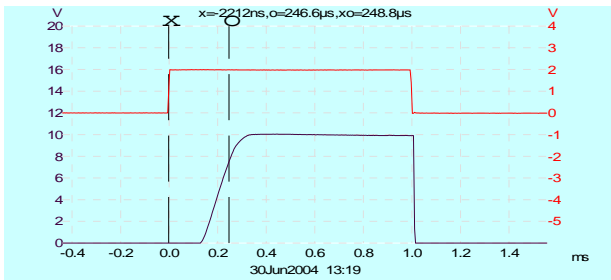

Figure 6. Turn-on delay is 248.8 μ S

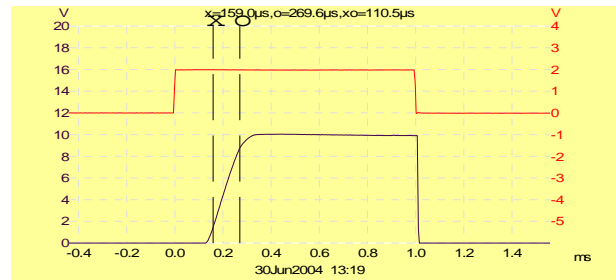

Figure 7. Rising time is 110.5 μ S

Control current is 30 mA or about 7.5 VDC

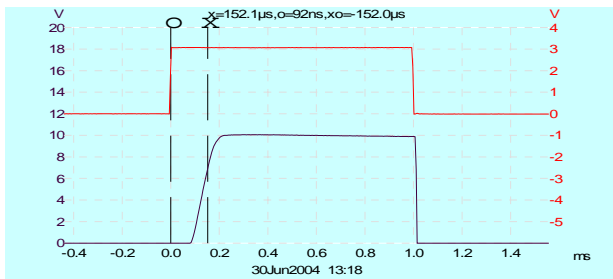

Figure 8. Turn-on delay is 152.0 μ S

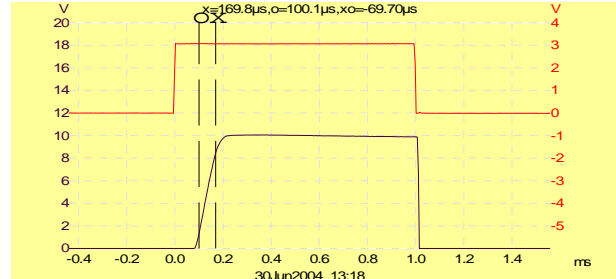

Figure 9. Rising time is 69.7 μ S

IV. Switching time test – Load – 7 VDC, 3A, control signal 5 mA, 120VAC, 60Hz

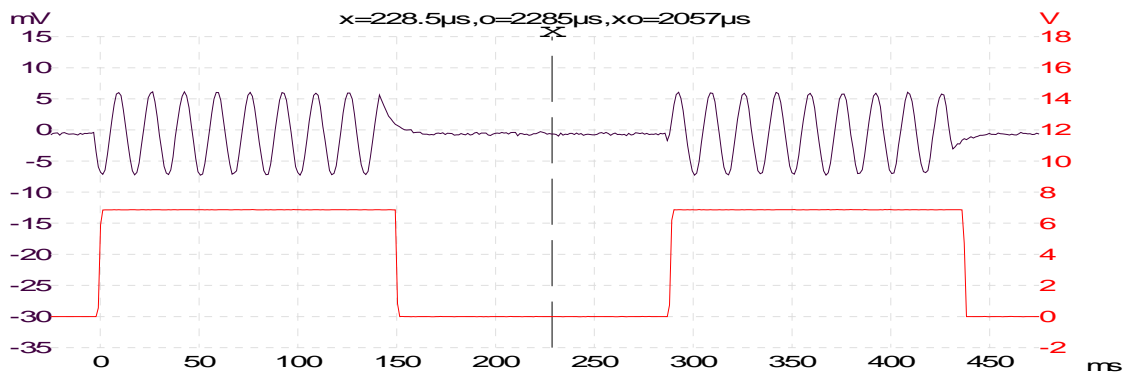

Figure 10. Top line is a control signal and bottom line is a load signal

Solid State I/O relays to replace I/O modules

AC input, DC and AC/DC output – MOSFET type

OUTPUT SPECIFICATIONS

(We rated our SSR's for the maximum current without a heat sink)

Model Number	Package	DC & DC/AC output	AC input Id (A) cont.	Idm (A)	p/n
D1A30D12/120	SIP4, mini	0 – 30 VDC	75-140 12 A rms	300	EDR82492/9
D1A55D10/120	SIP4, mini	0 – 55 VDC	75-140 10 A rms	200	EDR82491/9
D1A60D3/120	SIP4, mini	0 – 60 VDC	75-140 3 A rms	80	EDR82490/9
D1A100D2/120	SIP4, mini	0 – 100 VDC	75-140 2 A rms	70	EDR82493/9
D1A200D2/120	SIP4, mini	0 – 200 VDC	75-140 2 A rms	70	EDR82494/9
D2A500D1/120	SIP4	0 – 500VDC	75-140 1.3 A rms	30	EDR82495/9
D1A650D1/120	SIP4	0 – 650 VDC	75-140 1 A rms	7	EDR82515/9
D1A30A11/120	SIP4, mini	+/- 30VDC (21 VAC)	75-140 11 A rms	120	EDR82496/9
D1A55A8/120	SIP4, mini	+/- 55VDC (38 VAC)	75-140 8 A rms	160	EDR82497/9
D1A60A3/120	SIP4, mini	+/- 60 VDC (42 VAC)	75-140 3 A rms	70	EDR82498/9
D1A100A2/120	SIP4, mini	+/- 100 VDC (70 VAC)	75-140 2 A rms	50	EDR82500/9
D1A200A2/120	SIP4, mini	+/- 200 VDC (140 VAC)	75-140 2 A rms	48	EDR82501/9
D2A350A1/120	SIP4	+/- 500 VDC (350 VAC)	75-140 1 A rms	25	EDR82502/9
D1A650A1/120	SIP4	+/- 650 VDC (450 VAC)	75-140 .9 A rms	6	EDR82516/9
D1A30D12/240	SIP4, mini	0 – 30 VDC	180-280 12 A rms	300	EDR82492/10
D1A55D10/240	SIP4, mini	0 – 55 VDC	180-280 10 A rms	200	EDR82491/10
D1A60D3/240	SIP4, mini	0 – 60 VDC	180-280 3 A rms	80	EDR82490/10
D1A100D2/240	SIP4, mini	0 – 100 VDC	180-280 2 A rms	70	EDR82493/10
D1A200D2/240	SIP4, mini	0 – 200 VDC	180-280 2 A rms	70	EDR82494/10
D2A500D1/240	SIP4	0 – 500VDC	180-280 1.3 A rms	30	EDR82495/10
D1A650D1/240	SIP4	0 – 650 VDC	180-280 1 A rms	7	EDR82515/10
D1A30A11/240	SIP4, mini	+/- 30VDC (21 VAC)	180-280 11 A rms	120	EDR82496/10
D1A55A8/240	SIP4, mini	+/- 55VDC (38 VAC)	180-280 8 A rms	160	EDR82497/10
D1A60A3/240	SIP4, mini	+/- 60 VDC (42 VAC)	180-280 3 A rms	70	EDR82498/10
D1A100A2/240	SIP4, mini	+/- 100 VDC (70 VAC)	180-280 2 A rms	50	EDR82500/10
D1A200A2/240	SIP4, mini	+/- 200 VDC (140 VAC)	7180-28 2 A rms	48	EDR82501/10
D2A350A1/240	SIP4	+/- 500 VDC (350 VAC)	180-280 1 A rms	25	EDR82502/10
D1A650A1/240	SIP4	+/- 650 VDC (450 VAC)	180-240 .9 A rms	6	EDR82518/10

All relays can be made in a panel mount box (0.82”H x 2.7”L x 2.0”W), please replace “D1” or “D2” with “D7”

Speed and frequency properties of all D1N-types relays are close to the p/n EDR82490. There is some differences for varies relays and all depended on the output power. Please request a specific data sheet if that is important for your application.

In the same packages, we manufacture a family of miniature, low power Solid State Relays, built with MOSFETs. Those relays designed for an extremely small input control current. Only 3.0 mA @ 2.6 VDC required to operate. Please request a data sheet 7090 for p/n EDR82804. Relays were designed as a replacement of a SSR with a TRAIC or SCR output in applications where a low power consumption and low leakage current are must.

The above is a small list of EDR's solid-state modules (relays, I/O and breakers). Most of our products (about 72%) are manufactured to meet customers' specifications. You're welcome to generate a new p/n from the following page to satisfy your requirements or just send us email info@vsholding.com with the input and output requirements and we'll offer you a part number, data sheet and the delivery schedule.

A cost of a Solid State Relay is very much tied to an ordered volume, in most cases a relay costs in low teens in order of 1000 or more.

Ordering Instruction

A part description will be marked according to the description below but p/n EDRxxxxx will stay the same for already items in circulation (already sold).

D **a** **b** **c** **e** **f** **/h** **/i** **/k** **/z** **/0** **/v**

“D” is for our standard packages.

(a) Package dimensions

1	0.615”H x 1.48”L x 0.290”W
2	1.15”H x 1.75”L x 0.4”W
3	1.15”H x 1.75”L x 0.8”W
4	1.15”H x 2.0”L x 0.92”W
5	1.15”H x 2.8”L x 1.15”W
6	DIP24, 0.375”H x 0.925”L x 0.53”W
7	panel mount, 0.82”H x 2.7”L x 2.0”W

(b) Speed - A device’s ability to turn ON/OFF output terminal(s) per second

L	a low speed relay/switch, rated DC - 800 Hz, direct driving control, SIP4
A	a low speed relay/switch, AC input relays, SIP4
N	a medium speed relay/switch, rated DC - 25 KHz, direct driving control, SIP4
G	a medium speed relay/switch, rated DC - 25 KHz, low current control and power, SIP5
F	a fast relay/switch, rated DC - 800 KHz, low current control and power, SIP5
S	a super-fast relay/switch, rated DC - 1.4 MHz, low current control and power, SIP5
U	a super-fast relay/switch, rated DC - 1.2 MHz, direct driving control, SIP4

(c) Voltage - A maximum allowed voltage between output terminals

It must be replace with any of offered voltage, 30VDC, 45VDC, 75VDC, 100VDC, 200VDC, 500VDC, 650VDC, 800VDC, 900VDC, 1000VDC and 1100VDC, 1400VDC and 1700VDC.

Note: In an “AC” -relay a voltage specified a peak-to-peak maximum voltage and the maximum VAC can be calculated by multiplying a maximum allowed voltage by factor of 0.7.

(e) A relay can be use to control DC or AC/DC power

A	- a relay/switch designed to switch/chop an AC power
C	- a relay/switch with a normal close contacts
D	- a relay/switch designed to switch/chop a DC power

(f) A maximum allowed RMS CURRENT (Ampere) without a heat sink.

(h) We offer several standard control voltages 5VDC, 12VDC, 24VDC, 48VDC, 3-20VDC and 18-38VDC. Please specify the input control voltage, as for example D1L30D12/xx. Replace xx with a 3, 5, 12, 24, 48, 3-20 and 18-38 that is for 3VDC, 5VDC, 12VDC, 24VDC, 48VDC, 3-20VDC and 18-38VDC. Respectful control voltage represented at the end of part number in the following way, for an example EDR82653/1 and EDR82653/8. Both relays are almost the same and difference is only an applied control voltage, “1” if for 3VDC and “8” is for 18-38VDC;

<u>Control Voltage</u>	<u>Representation</u>	<u>Control Voltage</u>	<u>Representation</u>	<u>Control Voltage</u>	<u>Representation</u>
3VDC	1	5VDC	2	12VDC	3
24VDC	4	48VDC	5	26VDC	6
3-20VDC	7	18-38VDC	8	75 – 140 VAC	9
180-280VAC	10				

(i) A power supply required for a relay with an internal DC/DC converter. We offer several standard voltages 5VDC, 12VDC, 24VDC and 48VDC.

(k) Output terminals configurations

“N” or nothing	SPST or 1 Form A output terminals
“NN”	2SPST or 2 Form A output terminals
“NNN”	3SPST or 3 Form A output terminals
“T”	TOTEM output, break-before-make termination or NO-NO
“CN”	SPDT

(z) A relay/switch built with following standard isolations

“L” type relay is 2500 V
“N” type relay is 3000V, 4000VDC (“H4”) and 5200 (“H5”) VDC.

(0) Screening option, (NONE) for industrial, B for Class B, and S for Class S

(v) a Veri-Slope option.

Examples:

D3F1000D3/4-32/5 - a fast relay/switch designed to work with up to 1000 VDC and capable of 3 Ampere of rms. A control voltage can be any from 4VDC until 32VDC and required 5VDC to operate properly, SIP5 package.

D3N500A10/12/12 - a medium speed relay/switch designed to withstand 500VDC peak-to-peak or 350VAC and 10 Ampere of rms. A control voltage is 12VDC and the power supply is 12VDC, SIP4 package.