



Electronic Design & Research
<http://www.vsholding.com>

Technology for people's ideas

P/N EDR82909 is a fuzzy logic DIN-driver

Designed for D3G-, D3F- and D3S- families relays/switches

EDR's DIN-driver designed for various industrial applications and easy interfaced with a PLC, I/O cards and control switches. The DIN RAIL especially useful with a high-speed Solid State Relay, for a high power analog switch applications, as a 1/2 or a full (H) bridge driver.

The EDR82909/B designed to driver two and EDR82909/F drives four of EDR's D3G- and D3F-types relays in a 1/2 and H-bridge (full bridge) configurations. It can be use as a powerful analog, high frequency switch to provide a break-before-make commutation. The EDR82909 is a high frequency driver and optimized to drive two or four Solid State Relays in the break-before-make-synchronized topology. Combined with EDR's made relays/switches the EDR82909 drives source and sink up to 30A rms current. The EDR82909 also features a three-state PWM input will prevent a negative transient on the output voltage when the input is being shut down. The EDR82909 has the capacity to switch efficiently at frequency up to 800 KHz. The DIN RAIL has an internal logic circuitry that prevents shoot-through current even at a high switching frequency. A dead time is very easily can be changed by two capacitors, one of each cycle. The timing could the same or different based on the value of each capacitor to meet variety applications and R&D.

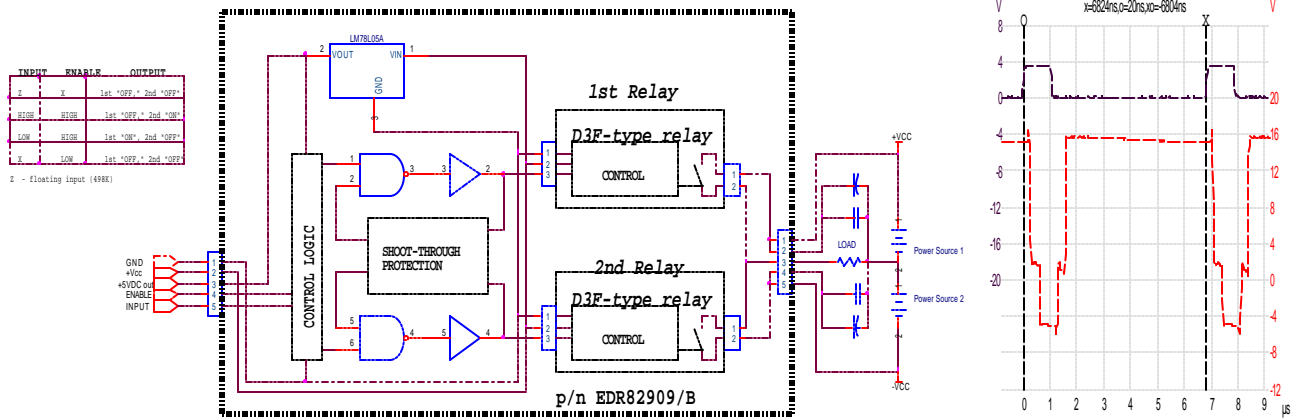

Simplified schematic of the EDR82909/B and a load hook-up in a 1/2 bridge driver application

Product Highlights

- Drives two (EDR82909/B) and four (EDR82909/F) EDR's made D3G and D3F- types Solid State Relays/Switches
- Electrical isolation input/output is 3000V or 5200V
- Switching frequency DC to 800 KHz
- Switching current from 0A till 30A rms
- Switching voltage from 0V till 2500 V
- Duty cycle: 0.. 100%
- Input and enable inputs are low power, CMOS
- Shoot-Trough Protection
- Three-State PWM Input for Power Stage Shutdown
- Non of relays activates when the input if floating
- A single power supply
- Matching Delay Between Inverting and No-inverting outputs
- Fussy logic or a three-state input allows easy control of either relay
- The enable can be use for PWM and shot-off
- The input can be use to indented control of either relay
- Add-on p/n EDR82915 allows a precise output power control

Applications

- Inverters
- A low cost Motor driver
- Converter
- Power engineering
- Laser driver and radiology
- RF power driver
- Analog switch
- Power Switching
- Power-Supply Modules
- 1/2 bridge and full-bridge driver
- Formatting a bio-polar pulse
- Assembling a SPDT and a dual SPDT configuration

Electronic Design & Research Inc. * 7331 Intermodal Drive *** Louisville, KY *** 40258**

Tel: 502-933-8660; Fax: 502-933-3422; Sales: 800-336-1337; e-mail: info@vsholding.com

DIN-driver as a full-bridge driver with four EDR's relays

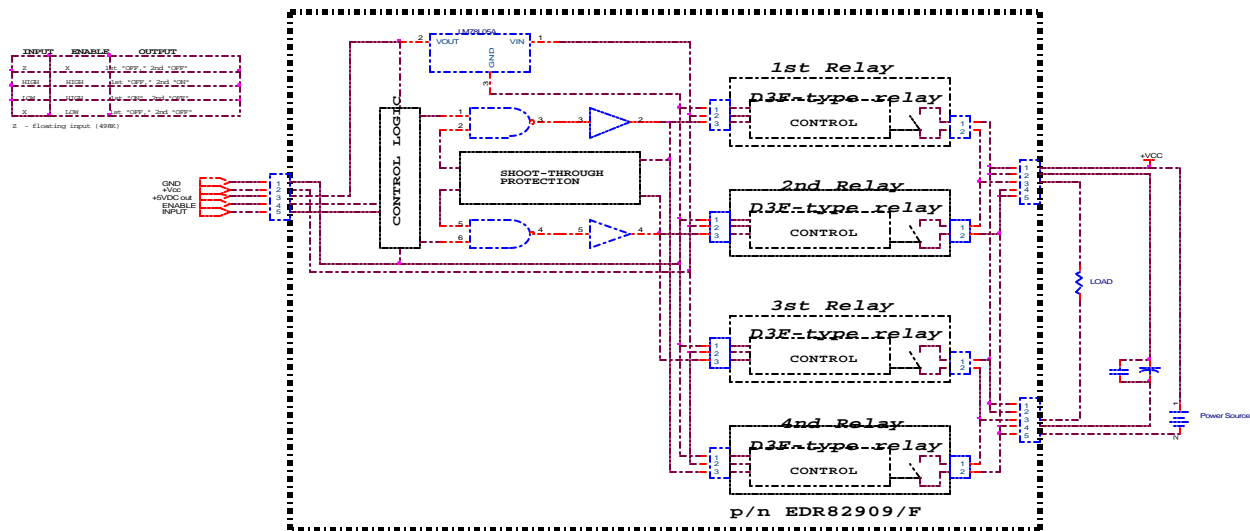

Simplified schematic of the EDR82909/B and a load hook-up in a full-bridge driver application

Functional Pin Description

GND (pin 1)

GND is the ground pin. All control signal and power supply to relays are reference to this node.

Vcc (pin 2)

Connect the Vcc pin to a + of a bias supply. The Vcc depends on what type of relays being used. It could be 5VDC or 12VDC.

+5VDC output (pin 3)

The +5VDC is the output from an internal voltage regulator when +12VDC applied onto Vcc (pin2). It is a low power source and can be use for an external applications but an aggregated load current cannot exceed 50 mA. There is no limit set for the current if Vcc (pin 2) is 5VDC because it passed through.

Enable (pin 4), the low threshold is 1.0V and the high is 2.0V

It is a dual use control (enable) input. Connect this pin to HIGH (+5VDC) or left unconnected to enable the DIN-driver. The LOW is disabled the driver. This input can be use for PWM applications.

INPUT (pin5), from 1.7V to 3.3V is off

The INPUT is the fuzzy or three-state input and control output relays. An applied signal can enter three distinct states during operation, 0V to 1.7V, 1.7V to 3.3V and 3.3V to Vcc, as it shown on the voltage diagram below. This input can be used to reverse polarity (direction) of a DC Motor.

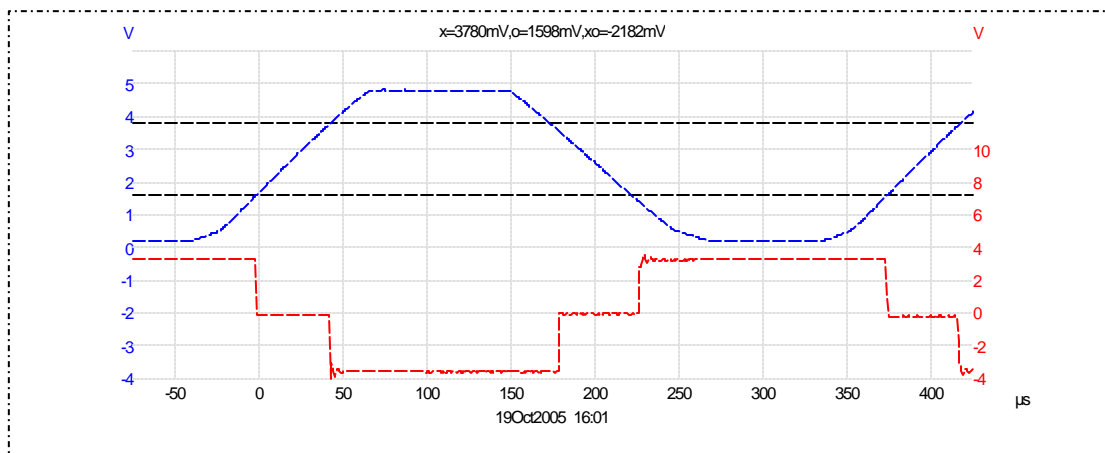

Voltage-timing diagram of the INPUT signal (top) and relays output (bottom), for demonstrating purpose slopes of the input signal set to a slow rise and fall transitions

Ordering Information

EDR82909/V/XX

** replace “V” with “B” for a two relays to implement ½ bridge driver, and with “F” for a four relays to implement a full-bridge driver

** replace “XX” with either 05, 09, 12, 15, 24 or 48 with the required power supply (Vcc). The power supply has to be chosen by the type of relay to be installed on the DIN-driver.

Recommended Operating Conditions

	MIN	TYP	MAX
Supply Voltage, Vcc for EDR82909/V/05		5VDC +/-5%	
Supply Voltage, Vcc	depended on the module	XX +/-10%	
Supply Current Icc, mA	(no relay installed), Vcc=5VDC		1.0
Ambient Temperature Range		-10°C to 90°C	
Input (pin 5) mA		0.25	
The first threshold (pin 5), V			1.7
The second threshold (pin 5), V	3.3		
Enable (pin 4), LOW threshold, V	1.0		
Enable (pin 4), HIGH threshold, V			2
Shoot-Trough Protection, adjustable and set by two capacitors, for 200pF		0.324 μS	

Two D3G-type relays mounted on the EDR82909 for a high frequency chopping

