



Electronic Design & Research
<http://www.vsholding.com>

Technology for people's ideas

Highly reliable, fast, 1/2 bridge driver/switch

Isolated, SPDT, ultra fast switches

Designed to switch kilowatts of power in nanoseconds

Fussy-logic controlled driver with a shoot-through protection offered with a various output voltages and currents to satisfy many industrial applications, up to 1,700V relays made with MOSFET and up to 2500V with IGBT. The "T" family also features a three-state PWM Tinput that works well together with most multiphase PWM controllers. A shoot-through protection is integrated to prevent both outputs from conducting simultaneously. The "T" – driver interfaces the best with tri-state logic.

Features:

- Push-pull output stage for up to1,000 A peak
- Wide Analog Signal Range +/- 2,500V
- Chopping frequencies up to 800 KHz
- Low "ON" resistance (MOSFET) Milliohms
- Low Vce saturation (IGBT) 2V average
- High Current Capability, AC/DC switching:
- D3S-package up to 24 A
- D4S-packageup to 76 A
- Custom packagingup to 1000A
- Available -- Unidirectional and bi-directional relays/switches, or for a VDC or VAC power.
- Available – SPDT (3 pins) and DPST (NO/NC or 4 pins)
- Short propagation delay input-output 550 nS
- Try-state outputs input floating
- Break-Before-Make Delay (Typ.) 220 nS
- Fast Switching Action:
- Ton100 nS
- Toff 100 nS
- TTL, CMOS and LMOS Compatible
- Three-State PWM input for OFF/OFF output terminals
- Single Power Supply5VDC, 12VDC or 24VDC
- Fussy Logic Input:
- ON for "NO2" 0-1.7 V
- ON for "NO1" 3.3V-5V
- High input-output isolation 2,750 V

Applications:

- Bi-directional switch
- 1/2 bridge driver for AC and DC motors
- Video signal termination
- High Energy pulse formation
- Two relays combined for H-bridge driver
- High power, High frequency driver
- Latch and High-speed solenoid driver
- High Energy, Bi-polar pulse formation
- A switch for redundant supply systems
- High Frequency Analog Switch
- Audio Switching
- Automatic Test Equipment
- Communication Systems
- Analog Selector Switch
- AC and DC power switch
- Audio Signal Multiplexing
- Servo-Motor driver
- Pulse-Width modulation
- High Frequency DC/DC Converters
- High Input Voltage DC/DC Converters
- Flashlamp supply for pumping solid-state laser
- Driver for a powerful IGBT and large modules
- Plasma and Electrostatic Paint
- Ultrasonic generator

The EDR's Solid State Drivers use proprietary and unique design to deliver fast, reliable, bounce-free switching in a compact SIP packages. They are an ideal solid-state replacement for large reed and electromechanical (EM) relays. Compared to this old electromagnetic technology, the EDR's SSRs offer significantly lower drive current, small package size, superb speed, high power DC commutation, no susceptibility to magnetic interaction and solid state reliability. All of these are key requirements for the design of today's complex low-power, fast and long-lasting products.

EDR's family of "T" – type Solid State Relays/Switches designed for speed, the H3FxxDxx and more powerful D4FxxTxx relays/switches have the capacity to efficiently switch DC or AC and can deliver a single shorter than 0.7 μS pulse width. The "T" family SSR, a half-bridge MOSFET/IGBT driver is designed to operate at frequencies up to 800 KHz (8 KHz PWM for 1% to 100% duty cycle) and is an ideal choice for high-speed applications such as motor control, SMPS (switch mode power supplies), laser diode driver or a high frequency ultrasound cleaner. The "T" driver/switch can be used in pairs for a full-bridge operation, or triplets in three-phase brushless DC motor driver applications.

A 1.2 MHz relay/switch is also available with ability to deliver a powerful a > 100 nS pulse.

Electronic Design & Research Inc. ** 7331 Intermodal Dr. ** Louisville ** KY 40258
Tel: 502-933-8660; Fax: 502-933-3422; Sales: 800-336-1337; e-mail: vsholding@vsholding.com

Functional diagram of the "T" family, 1/2 bridge driver

EDR's solid-state relays combined our state-of-the-art SIP6, SIP7 and SIP9 (a custom and with screw-type terminals enclosures are available) encapsulated, vertical-construction packaging with high performance to give our customers a reliable product with a significant saving in board space compare to other relays. EDR rates relays by the maximum current and no a heat sink required. We believe that removes confusing of what a relay is capable of. Below is a functional diagram of the "H" family and we can make for you a relay with any voltage and current, please be reasonable.

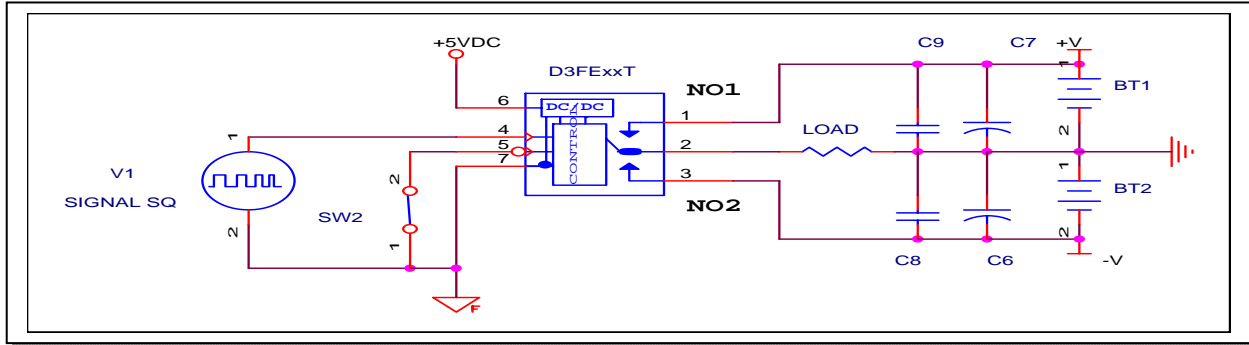

Typical applications

A **1 FORM C**, or a SPDT relay, or a 1/2 bridge driver – the T3Fcdv/ can be use as a general-purpose motor driver with a dual-power supply Capable of operating in extremely harsh environments, this device can withstand high ambient temperature, output overload, and repeated power supply transient voltages without damage. The relay can be used in triplets in three-phase brushless DC motor-driver applications.

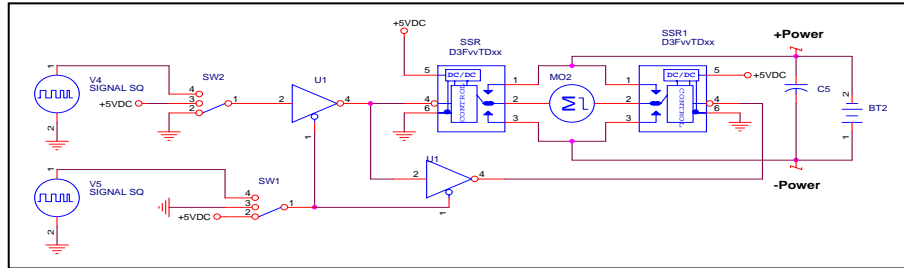

EDR's "T" relays can be used in pairs to drive both windings of a bipolar stepper motor or bi-directional control for full-bridge operation with a single-output power source.

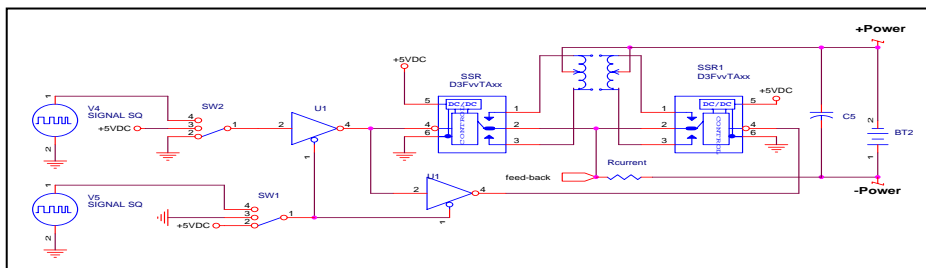

Stepper-Motor Driver

Solid State Relay/Switch with a fuzzy-logic control input

A unique feature of the "H-" type relay/driver is a fuzzy-logic or three-state input control. The control input designed for the maximum application flexibility and simplicity in interfacing. It is a high impedance input and any 5V CMOS logic can be used to control it. The best result can be obtained with tri-state output logic, like a bus-driver IC chips or a CPU. The control input has three defined levels, as that can be seen on the figure, below: 0-1.7V, 1.9-3.2V, and 3.4-5V. That voltage variation allows targeting control any one of terminals or turn "OFF" the driver (terminals) all together. If the control signal remains within the shutdown window (1.9-3.2V), the outputs (pins 1, 2 and 3) are disabled (NO/NO). When the control signal moves on either side of the "shutdown window", it is below 1.7V, or above 3.4V, the pair of terminals 1-2 and 2-3 will change a state from N.O. to N.C. respectfully. Otherwise, the control signal's rising and falling thresholds outline in the Electrical Specifications determine when the lower and upper gates are enabled.

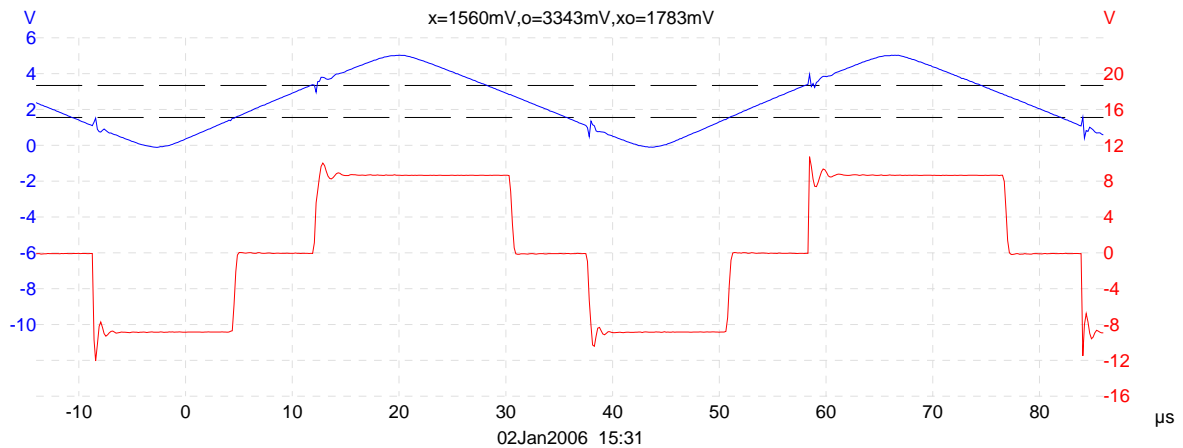

Figure shows a control signal (upper or blue) and a voltage on a load (below or red)

When a control signal (a tooth-wave was selected for a better illustration) rises above 3.34V it enables one pier and when it falls below 1.56V other pair of terminals conducts.

Shoot-Through Protection

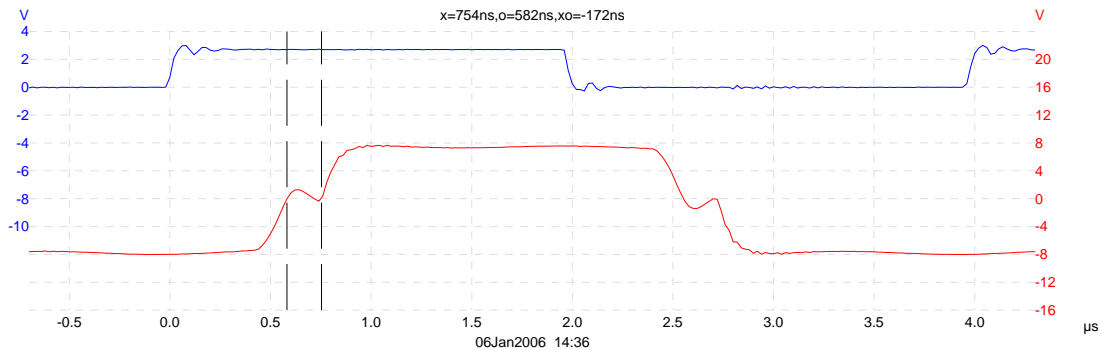

Figure shows break-before-make properties of the "T" type driver

The driver incorporated fixed shoot-through protection ("dead" time) to prevent upper and lower transistors from conducting simultaneously and shorting the power supply. The "dead" time as short as 80 nS for a low power and up to 1.5 μS for a high-power, high voltage drivers. The timing made during the production. The "dead" time was not designed to be change by an end-user. Please let us know if you need a different "dead" timing.



Electronic Design & Research
<http://www.vsholding.com>

Technology for people's ideas

EDR83914 - 500VDC, 2A High speed SPDT Relay/1/2 Bridge Driver

Isolated, a break-before-make switches

The EDR83914 (H3F500D3/5) belongs to the "H" family of a fussy-logic controlled relays offers needed flexibility that required in many industrial applications.

- Features:** Utilizes only 1.4 sq. in. of PCB area and only 1.15" tall
 1.8A continuously or up to 24 A pulse in a miniature package
 High sensitivity, even at high switching frequencies
 90 A surge current and only 0.22 Ohms on-state resistance

Please specify power supply and control voltage

Input Specifications:

Input Control Voltage (pin 4) see "order page"
 Nominal Current 0.3 mA
 Power Supply +Vcc (pin6) see the order page for selection

Output Specifications:

Operating DC voltage range 500 VDC
 Maximum continuous current 1.8 Arms rms
 Maximum surge current (IDM) - .1mS 90 A
 Continuous current (ID) - Pulsed 24 A
 Maximum on-state resistance 0.22 Ohm
 Rising time 0.017 μS
 Delay-on time 0.140 μS
 Falling time 0.027 μS
 Delay-off time 0.098 μS
 Maximum switching frequency 275 KHz

All specifications were giving without any heatsink at room temperature

General Specifications:

Ambient operating temperature range -35⁰ C to 75⁰ C
 Ambient storage temperature range -55⁰ C to 125⁰ C
 Dielectric Strength input-to-output 1,000VAC

Mechanical Specifications:

Weight (oz) .2
 Encapsulation Epoxies Etc. 50-2366RFR / 50-2366CFR

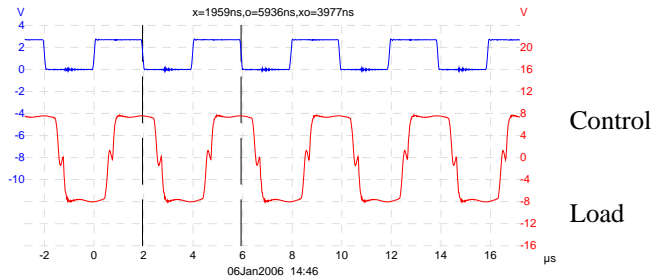
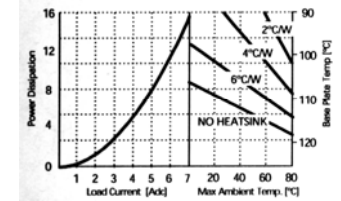
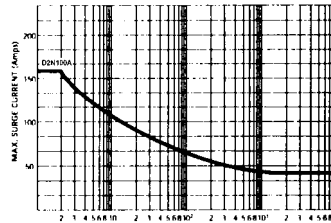

A sample of driving a load at 250 KHz

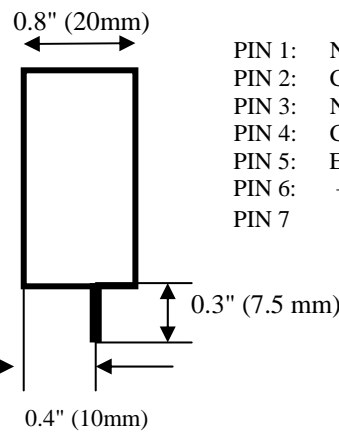
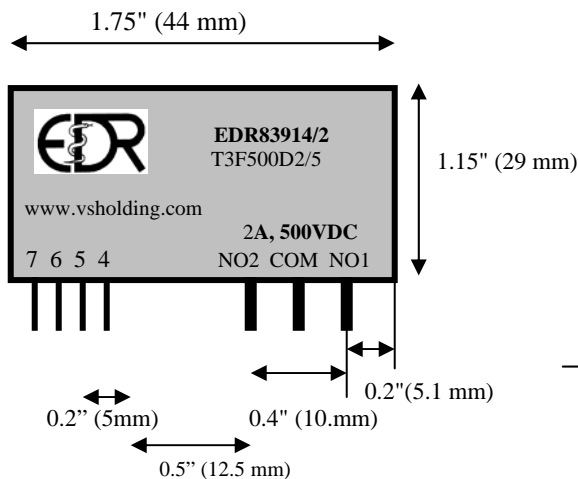

- PIN 1: NO1
- PIN 2: COM
- PIN 3: NO2
- PIN 4: Control Signal (CS)
- PIN 5: Enable (EN)
- PIN 6: + 5VDC
- PIN 7: GND

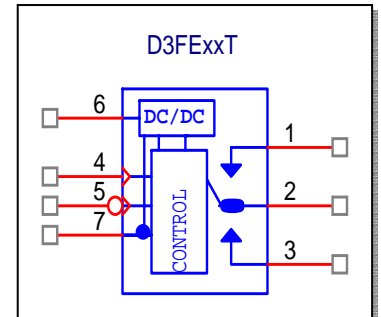

All Dimensions are in inches (millimeters).
 Dimensions for SIP7 package 1.15"H x 1.75"L x 0.8"W
 Terminals/solder for SIP7 package control -0.20", power -0.6"

Transient Protection: All loads are inductive, even ones that are not so obvious or labeled. An inductive load produces a harmful transient voltage, which is much higher than the applied voltage, when it is turned on and off. A SSR built with a MOSFET output acts as an ideal switch and can produce a seemingly "non-inductive" load, which can cause damage if not suppressed. A transient voltage suppressor, which is bi-directional for AC applied voltage and unidirectional for DC applied voltage, should be used to clamp excessive spikes.

Electronic Design & Research Inc. ** 7331 Intermodal Dr. ** Louisville ** KY 40258

Tel: 502-933-8660; Fax: 502-933-3422; Sales: 800-336-1337; e-mail: vsholding@vsholding.com

Input Electrical Characteristics (Ta = 25°C) for T3F500D3/5, p/n EDR83914/2

Characteristic	Test Condition	Min	Typ.	Max.	Unit
Control Voltage, low level threshold			1.7		V
Control Voltage, high level threshold			3.3		V
Enable (EN) threshold (pin 5)		1.0	2.0		V
Input Current			0.300		mA

Input Electrical Characteristics (Ta = 25°C)

Power Supply (pins 6), Vcc (200 mA maximum)	4.9	5	5.3	V
Maximum Vcc current at DC – 1.0 KHz		40		mA
Maximum Vcc Current at 275 KHz		200		mA

Switching time test – Load – 8.3 Ohm & 2.2 A

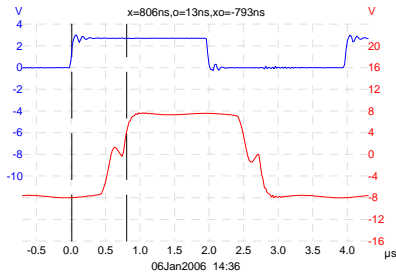

Figure 1 Turn-on delay is 793 nS

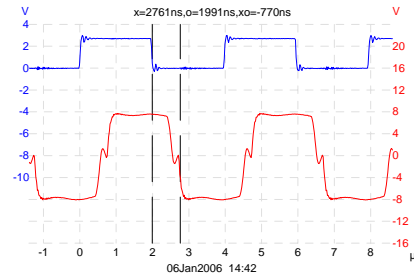

Figure 2 Turn-off delay is 770 nS

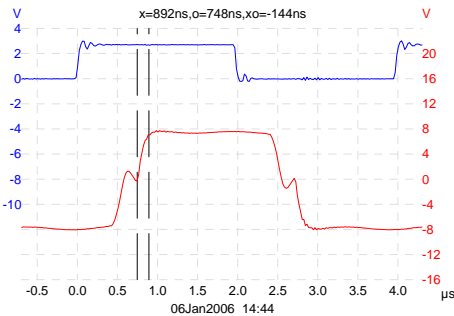

Figure 3 Rising Time is 144 nS

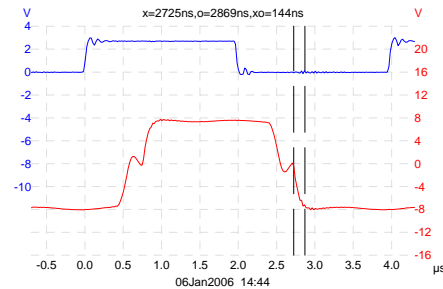

Figure 4 Fall Time is 144 nS

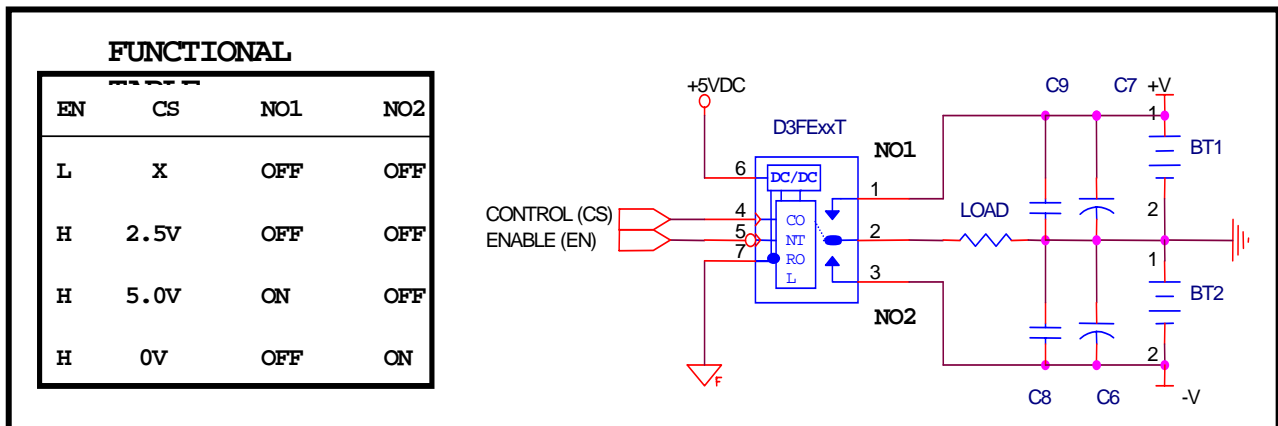

Fig. 5 Switching Time Test Circuit

The enable is connected to +5VDC via a 10K resistor and can be left floating.



Electronic Design & Research
<http://www.vsholding.com>

Technology for people's ideas

Powerful, Fast, Solid-State 1/2 Driver

Designed to deliver 84 KW of power in a microsecond

Features: Utilizes only 1.4 sq. in. of PCB area and only 1.15" tall
 3A continuously or up to a 24A pulse at 10 μS pulse or 100 KHz
 High sensitivity, even at high switching frequencies
 At 20A current only 1.9 Vce saturated
 140 A pulse and 35 A continuously at 110 °C
 Please specify power supply and control voltage

Input Specifications:

Input Control Voltage (pin 4) see page #5
 Nominal Current 0.5 mA
 Power Supply +Vcc (pin 5) see the order page for selection

Output Specifications:

Operating DC voltage range 0 – 600 VDC
 Maximum continuous current 3 A rms at 10 KHz
 Maximum continuous current 1A rms at 200 KHz
 Maximum surge current (IDM) - .03mS 140 A
 Continuous current (ID) 24A
 Maximum Vce 2.1 V at 20A
 Rising time 0.025 μS
 Delay-on time 0.220 μS
 Falling time 0.035μS
 Delay-off time 0.200 μS
 Maximum switching frequency 400 KHz

General Specifications:

Ambient operating temperature range -45° C to 85° C
 Ambient storage temperature range -55° C to 125° C
 Dielectric Strength input-to-output 3,000VAC

Mechanical Specifications:

Weight (oz) .2
 Encapsulation Epoxies Etc. 50-2366RFR / 50-2366CFR

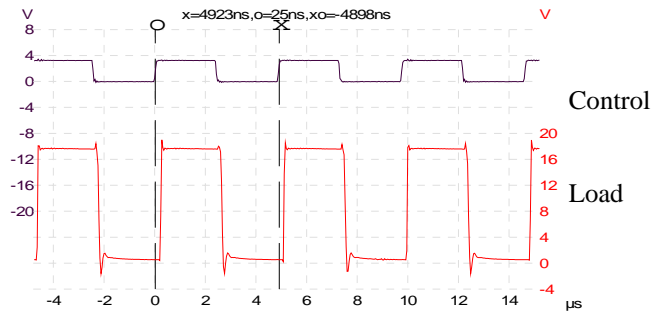
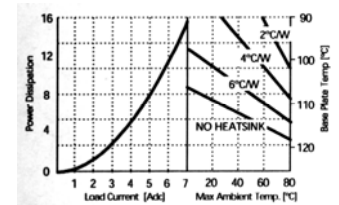
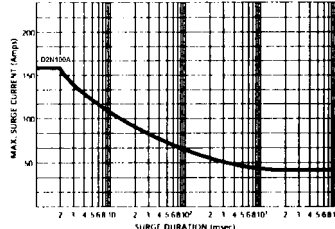

Pulse train (frequency) about 204 KHz

- PIN 1: + LOAD, +V
- PIN 2: common LOAD, C
- PIN 3: - LOAD, -V
- PIN 4: Control Signal, CS/F
- PIN 5: +Vcc
- PIN 6: Power Supply return, GND

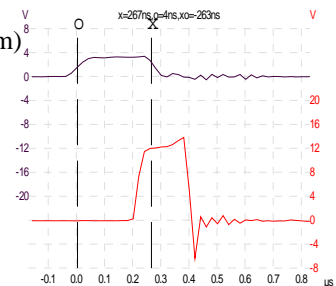
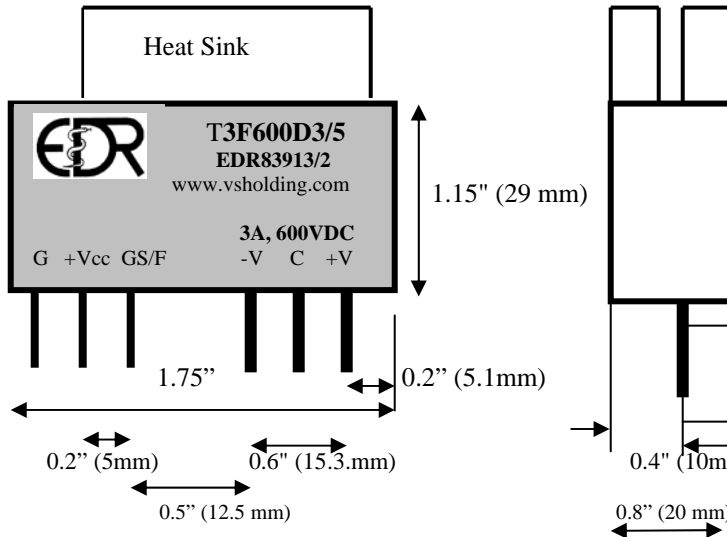

Pulse width 263 nS, 10A (single power0)

All Dimensions are in inches (millimeters).
 Dimensions for SIP4 package
 Terminals/solder for SIP4 package

1.15"H x 1.75"L x 0.8"W
 control -0.40", power -0.6"

Transient Protection: All loads are inductive, even ones that are not so obvious or labeled. An inductive load produces a harmful transient voltage, which is much higher than the applied voltage, when it is turned on and off. A SSR built with a MOSFET output acts as an ideal switch and can produce a seemingly "non-inductive" load, which can cause damage if not suppressed. A transient voltage suppressor, which is bi-directional for AC applied voltage and unidirectional for DC applied voltage, should be used to clamp excessive spikes.

Electronic Design & Research Inc. ** 7331 Intermodal Dr. ** Louisville ** KY 40258

Tel: 502-933-8660; Fax: 502-933-3422; Sales: 800-336-1337; e-mail: vsholding@vsholding.com



Electronic Design & Research
<http://www.vsholding.com>

Technology for people's ideas

100VDC, 10A, 100 KHz 1/2 driver/switch

Features: Utilizes only 1.4 sq. in. of PCB area and only 1.15" tall
 10 A continuously or up to a 100A pulse at 10 μ S pulse
 High sensitivity, even at high switching frequencies
 80 A pulse and 3 A continuously at 110 °C

Please specify power supply and control voltage

Input Specifications:

Input Control Voltage (pin 4) see
 Nominal Current 0.5 mA
 Power Supply +Vcc (pin 5) see the order page for selection

Output Specifications:

Operating DC voltage range -100 VDC to +100VDC
 Maximum continuous current 10 A rms at 10 KHz
 Maximum continuous current 1A rms at 200 KHz
 Maximum surge current (IDM) - .03mS 440 A
 Continuous current (ID) 90A
 Pulsing current 100A
 Maximum resistance 0.010 Ohm
 Rising time 0.090 μ S
 Delay-on time 1,200 μ S
 Falling time 0.095 μ S (1 Ohm)
 Delay-off time 0.620 μ S
 Maximum switching frequency 100 KHz

General Specifications:

Ambient operating temperature range -45° C to 85° C
 Ambient storage temperature range -55° C to 125° C
 Dielectric Strength input-to-output 3,000VAC

Mechanical Specifications:

Weight (oz) .2
 Encapsulation Epoxies Etc. 50-2366RFR / 50-2366CFR

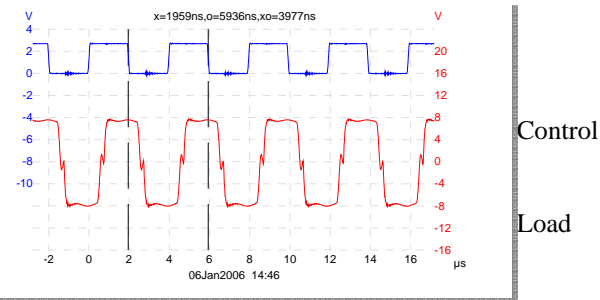
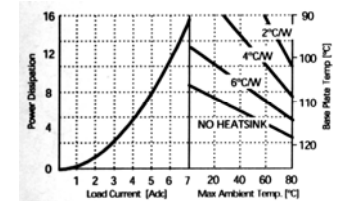
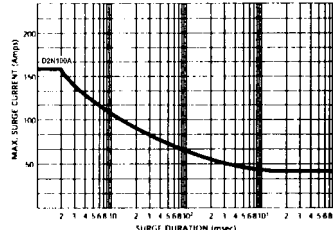

Pulse train (frequency) about 250 KHz

- PIN 1: + LOAD, +V
- PIN 2: common LOAD, C
- PIN 3: - LOAD, -V
- PIN 4: Control Signal, CS/F
- PIN 5: +5VDC
- PIN 6: Power Supply return, GND

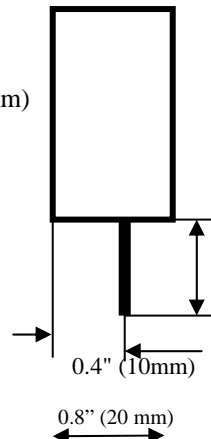
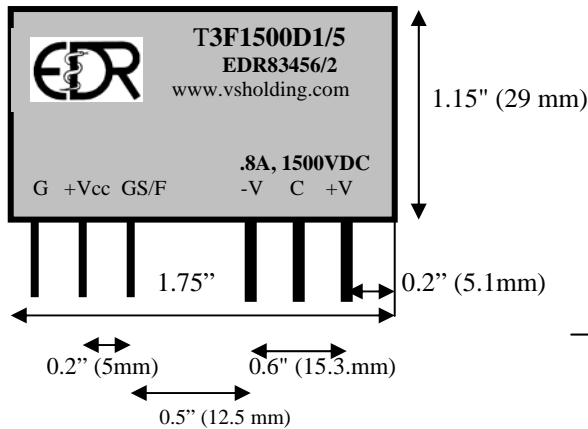

All Dimensions are in inches (millimeters).
 Dimensions for SIP4 package
 Terminals/solder for SIP4 package

1.15" H x 1.75" L x 0.8" W
 control - 0.40", power - 0.6"

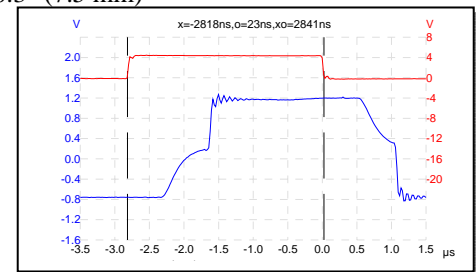

Transient Protection: All loads are inductive, even ones that are not so obvious or labeled. An inductive load produces a harmful transient voltage, which is much higher than the applied voltage, when it is turned on and off. A SSR built with a MOSFET output acts as an ideal switch and can produce a seemingly "non-inductive" load, which can cause damage if not suppressed. A transient voltage suppressor, which is bi-directional for AC applied voltage and unidirectional for DC applied voltage, should be used to clamp excessive spikes.

Electronic Design & Research Inc. ** 7331 Intermodal Dr. ** Louisville ** KY 40258

Tel: 502-933-8660; Fax: 502-933-3422; Sales: 800-336-1337; e-mail: vsholding@vsholding.com

Input Electrical Characteristics (Ta = 25°C) for T3F1500D10, p/n EDR83456

Characteristic	Test Condition	Min	Typ.	Max.	Unit
Control Voltage, low level threshold			1.7		V
Control Voltage, high level threshold			3.3		V
Input Current			0.300		mA

Input Electrical Characteristics (Ta = 25°C)

Power Supply (pins 6), Vcc (200 mA maximum)	4.9	5	5.3	V
Maximum Vcc current at DC – 1.0 KHz		40		mA
Maximum Vcc Current at 100 KHz		200		mA

Switching time test – Load – 1.0 Ohm & 4 A

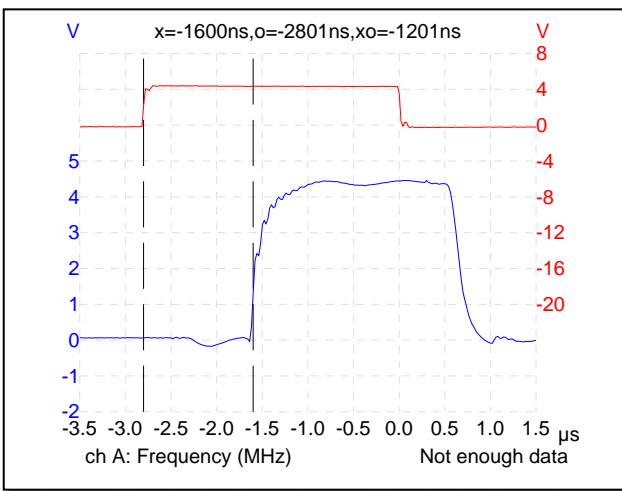

Turn-on delay is 1200 nS

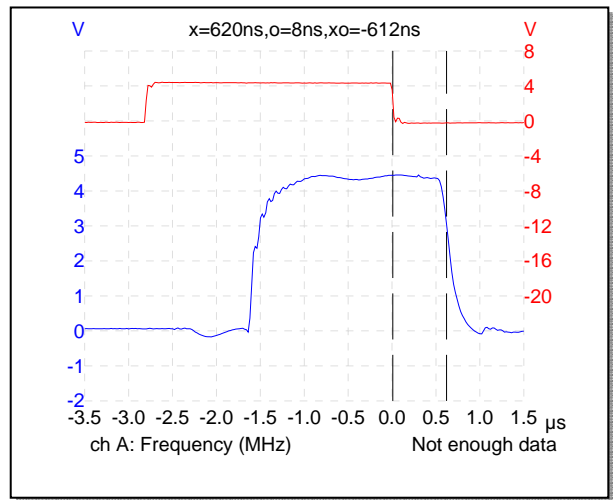

Turn-off delay is 612 nS

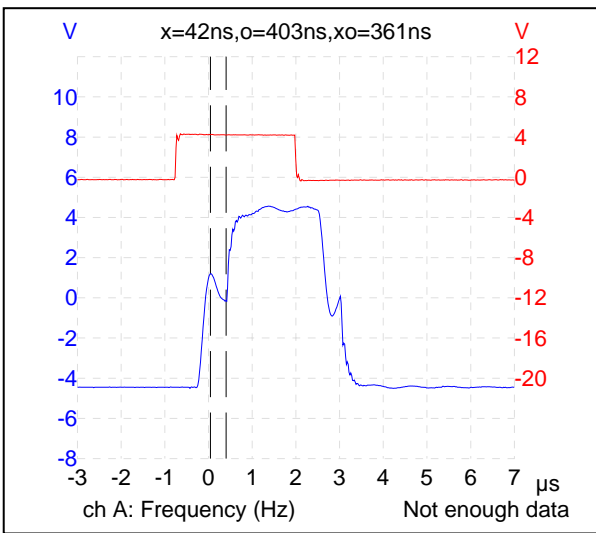

A “dead zone” on the rising front is 361 nS

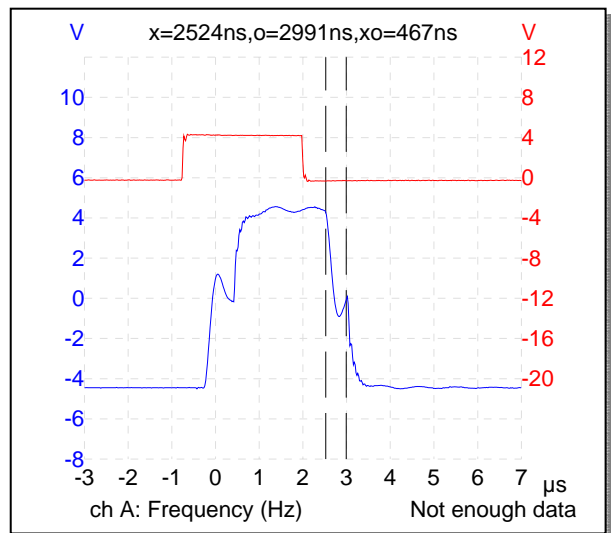

“Dead zone” on the falling front 4567 nS



Electronic Design & Research
<http://www.vsholding.com>

Technology for people's ideas

1500VDC, 0.8A, 200 KHz, 1/2 driver/switch

Features: Utilizes only 1.4 sq. in. of PCB area and only 1.15" tall
 0.8 A continuously or up to a 12A pulse at 10 μS pulse
 High sensitivity, even at high switching frequencies
 4 A pulse and 6 A continuously at 110 °C

Please specify power supply and control voltage

Input Specifications:

Input Control Voltage (pin 4) see specifications
 Nominal Control Signal Current 0.5 mA
 Power Supply +Vcc (pin 5) see the order page for selection

Output Specifications:

Operating DC voltage range – 1500 to +1500 VDC
 Maximum continuous current .8 A rms at 10 KHz
 Maximum continuous current .3 A rms at 200 KHz
 Maximum surge current (IDM) - .03mS 12 A
 Continuous current (ID) 4A
 Pulsing current 10A
 Maximum resistance 7 Ohm
 Rising time 37 nS
 Delay-on time 270 nS
 Falling time (depended on a load) 107 nS (60 Ohm)
 Delay-off time 330 nS
 Maximum switching frequency 200 KHz

General Specifications:

Ambient operating temperature range -45° C to 85° C
 Ambient storage temperature range -55° C to 125° C
 Dielectric Strength input-to-output 3,000VAC

Mechanical Specifications:

Weight (oz) .2
 Encapsulation Epoxies Etc. 50-2366RFR / 50-2366CFR

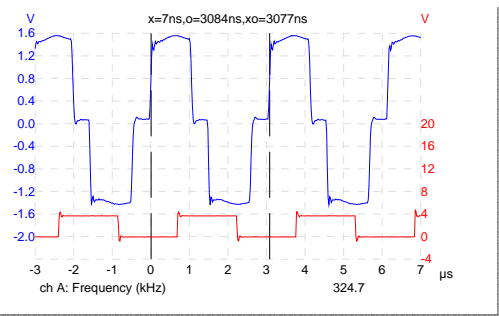
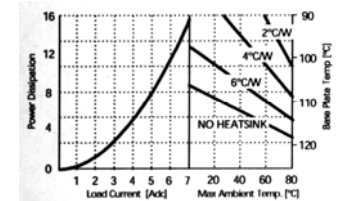
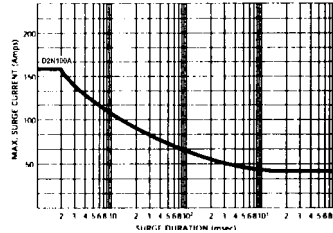

Control
 Load

Pulse train (frequency) at 324 KHz

- PIN 1: + LOAD, +1,500V
- PIN 2: common LOAD, C
- PIN 3: - LOAD, -1,500V
- PIN 4: Control Signal, CS/F
- PIN 5: +5VDC
- PIN 6: Power Supply return, GND

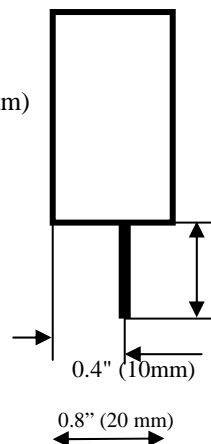
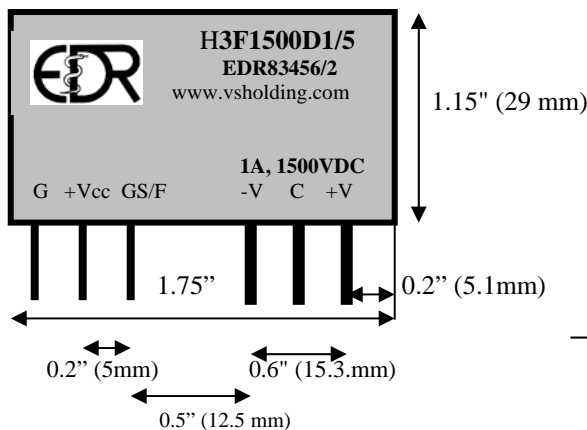

A single Pulse 280ns

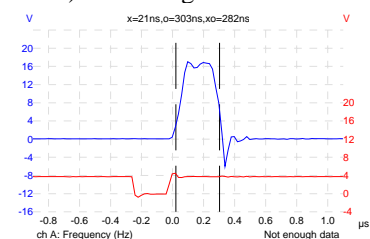

All Dimensions are in inches (millimeters).
 Dimensions for SIP4 package
 Terminals/solder for SIP4 package

1.15" H x 1.75" L x 0.8" W
 control - 0.40", power - 0.6"

Transient Protection: All loads are inductive, even ones that are not so obvious or labeled. An inductive load produces a harmful transient voltage, which is much higher than the applied voltage, when it is turned on and off. A SSR built with a MOSFET output acts as an ideal switch and can produce a seemingly "non-inductive" load, which can cause damage if not suppressed. A transient voltage suppressor, which is bi-directional for AC applied voltage and unidirectional for DC applied voltage, should be used to clamp excessive spikes.

Electronic Design & Research Inc. ** 7331 Intermodal Dr. ** Louisville ** KY 40258

Tel: 502-933-8660; Fax: 502-933-3422; Sales: 800-336-1337; e-mail: vsholding@vsholding.com

Input Electrical Characteristics (Ta = 25°C) for H3F100D10, p/n EDR82761

Characteristic	Test Condition	Min	Typ.	Max.	Unit
Control Voltage, low level threshold			1.7		V
Control Voltage, high level threshold			3.3		V
Input Current			0.300		mA

Input Electrical Characteristics (Ta = 25°C)

Power Supply (pins 6), Vcc (200 mA maximum)	4.9	5	5.3	V
Maximum Vcc current at DC – 1.0 KHz		40		mA
Maximum Vcc Current at 200 KHz		180		mA

Switching time test: Load – 60.0 Ohm & .4 A

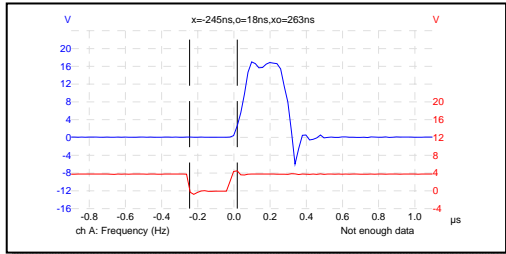

Turn-on delay is 263 nS

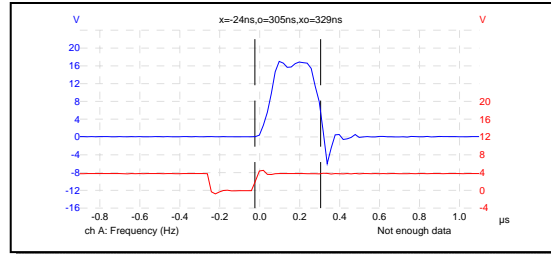

Turn-off delay is 329 nS

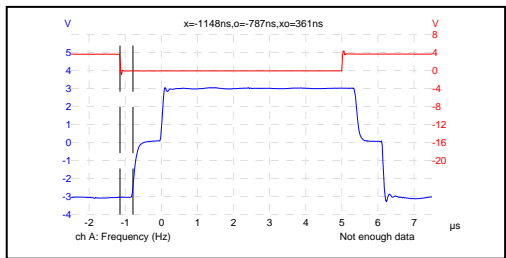

Turn-on delay is 361 nS

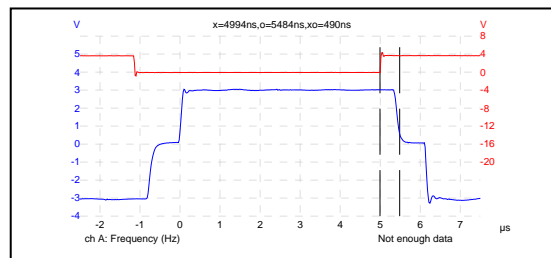

Turn-off delay is 490 nS

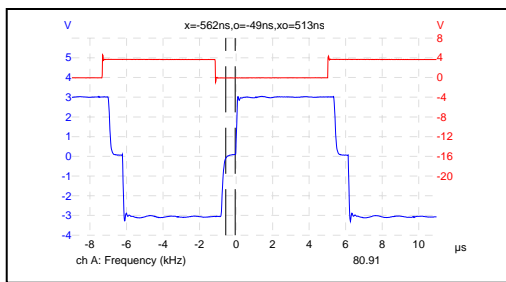

A “dead zone” on the rising front is 361 nS

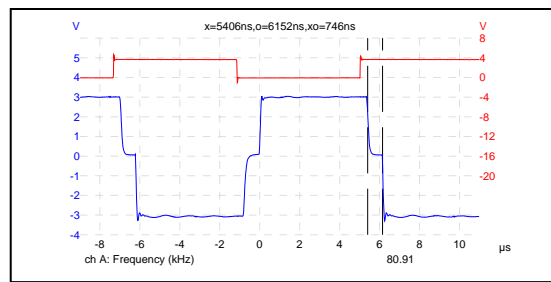

“Dead zone” on the falling front 4567 nS

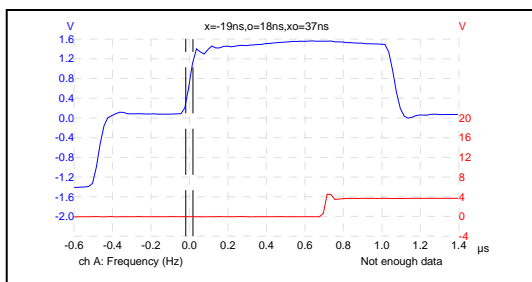

Rising slope is 37 nS

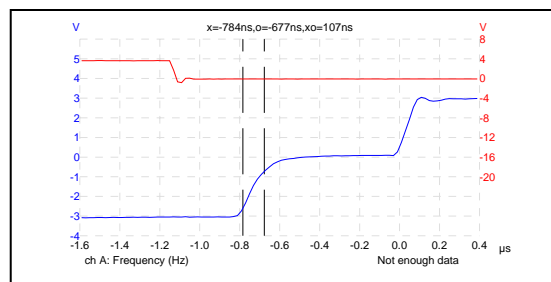

A “free” Falling slope is 107 nS. Time depended on the load' impedance

Selection and Ordering Instruction for EDR's made Solid State Modules such as Relays, Switches, Breakers, 1/2 and Full-bridge Drivers, etc.

Notes: During past ten years rapid development of new and additional products gave us no choice but to expend, modify and unify part descriptions. Below represent the third modification. Our modules description will be marked according to the specifications below but p/n EDRxxxx will stay the same for already items in circulation (already sold).

	<u>X</u>	<u>A</u>	<u>B</u>	<u>C</u>	<u>F</u>	<u>H</u>	<u>I</u>	<u>E</u>	<u>Z</u>	<u>0</u>
“X”	module type									
	D	Solid State Relay								
	T	Driver, such as 1/2-bridge or a SPDT relay which can work as a 1/2 driver								
	H	Full-bridge (H-bridge) Driver								
	V	Fast High Voltage Solid-State Switches with Nanoseconds rise time								
	B	Solid State Breaker and brakes control modules								

“A” package dimensions

1	0.615”H x 1.48”L x 0.290”W
2	1.15”H x 1.75”L x 0.4”W
3	1.15”H x 1.75”L x 0.8”W
4	1.15”H x 2.0”L x 0.92”W
5	1.15”H x 2.8”L x 1.15”W
6	DIP24, 0.375”H x 0.925”L x 0.53”W
7	panel mount, 0.82”H x 2.7”L x 2.0”W
8	DIN type enclosure, 2.36”H x 2.36” x 1.5”W, for 35mm DIN Rail

“B” Speed - A device's ability to turn ON/OFF output terminal(s) times per second

L	a low speed relay/switch, rated DC - 200 Hz, direct driving control
A	a low speed relay/switch, AC input relays
N	a medium speed relay/switch, rated DC - 25 KHz, direct driving control
G	a medium speed relay/switch, rated DC - 25 KHz, low current control and power
F	a fast relay/switch, rated up to DC - 350 KHz, low current control and power
S	a super-fast relay/switch, rated DC - 1.4 MHz, low current control and power
U	a super-fast relay/switch, rated DC - 1.2 MHz, direct driving control

“C” Output Voltage - A maximum allowed voltage between output terminals, up to 100kV
 It must be replace with required voltage and we offer the closest and highest value available.
Note: In an “AC” -relay a voltage specified a peak-to-peak maximum voltage and the maximum VAC can be calculated by multiplying a maximum allowed voltage by factor of 0.7

“F” A relay can be use to control either AC, DC or AC/DC power

A	- a relay/switch designed to switch/chop an AC/DC power
D	- a relay/switch designed to switch/chop a DC power
“none”	- relay with a SCR or TRIAC on the output to control only AC power

“H” A maximum allowed RMS CURRENT (Ampere) without a heat sink, up to 100A.
 A maximum current limited to a size of the enclosure (box). We can produce a device for any required current in a customer enclosure.

“I” Some of our products use an internal DC/DC converter no provide a power to the internal electronics.
Varieties voltages are available: 5VDC+/-5%, 12VDC+/-5%, 24VDC+/-5% and 48VDC+/-5%. For a wider input power voltage swing, please add “W” after the voltage. For an example, 24W is for 24V +/-12V.

“E” We offer several standard control voltages 5VDC, 12VDC, 24VDC, 48VDC, 3-20VDC and 18-38VDC. Please specify the input control voltage, as for example D1L30D12/xx. Replace xx with a 3, 5, 12, 24, 48, 3-20 and 18-38 that is for 3VDC, 5VDC, 12VDC, 24VDC, 48VDC, 3-20VDC and 18-38VDC. Respectful control voltage represented at the end of part number in the following way, for an example EDR82653/1 and EDR82653/8. Both relays are almost the same and difference is only an applied control voltage, “1” if for 3VDC and “8” is for 18-38VDC;

Control Voltage	Representation	Control Voltage	Representation	Control Voltage	Representation
3VDC	1	5VDC	2	12VDC	3
24VDC	4	48VDC	5	26VDC	6
3-20VDC	7	18-38VDC	8	90-120VAC	9

“Z” Output terminals configurations

“N” or nothing	SPST-NO or 1 Form A output terminals,
“NN”	2SPST, or 2 Form A output terminals, or DPST
“NNN”	3SPST, or 3 Form A output terminals
“C”	Normal Close output
“CN”	SPDT, or 1 Form C output terminals

“z” A relay/switch built with following standard isolations

“L” or “none”	type relay is 2500 V
“N”	type relay is 3000V, 4000VDC (“H4”) and 5200 (“H5”) VDC.

“0” Screening option, (NONE) for industrial, B for Class B, and S for Class S

Electronic Design & Research Inc. ** 7331 Intermodal Dr. ** Louisville ** KY 40258
 Tel: 502-933-8660; Fax: 502-933-3422; Sales: 800-336-1337; website: <http://www.vsholding.com>; e-mail: info@vsholding.com