



Electronic Design & Research  
<http://www.vsholding.com>

Technology for people's ideas

EDR83914 - 500VDC, 2A High speed SPDT Relay/1/2 Bridge Driver

**Isolated, a break-before-make switches**

The EDR83914 (D3F500TD3/5) belongs to the "T" family of a fussy-logic controlled relays offers needed flexibility that required in many industrial applications.

- Features:** Utilizes only 1.4 sq. in. of PCB area and only 1.15" tall  
 1.8A continuously or up to 24 A pulse in a miniature package  
 High sensitivity, even at high switching frequencies  
 90 A surge current and only 0.22 Ohms on-state resistance

Please specify power supply and control voltage

**Input Specifications:**

- Input Control Voltage (pin 4) see page #5  
 Nominal Current 0.3 mA  
 Power Supply +Vcc (pin6) see the order page for selection

**Output Specifications:**

- Operating DC voltage range 500 VDC  
 Maximum continuous current 1.8 Arms rms  
 Maximum surge current (IDM) - 0.1mS 90 A  
 Continuous current (ID) - Pulsed 24 A  
 Maximum on-state resistance 0.22 Ohm  
 Rising time 0.017 μS  
 Delay-on time 0.140 μS  
 Falling time 0.027μS  
 Delay-off time 0.098 μS  
 Maximum switching frequency 275 KHz

All specifications were giving without any heatsink at room temperature

**General Specifications:**

- Ambient operating temperature range -35<sup>0</sup> C to 75<sup>0</sup> C  
 Ambient storage temperature range -55<sup>0</sup> C to 125<sup>0</sup> C  
 Dielectric Strength input-to-output 3,000VAC

**Mechanical Specifications:**

- Weight (oz) .2  
 Encapsulation Epoxies Etc. 50-2366RFR / 50-2366CFR

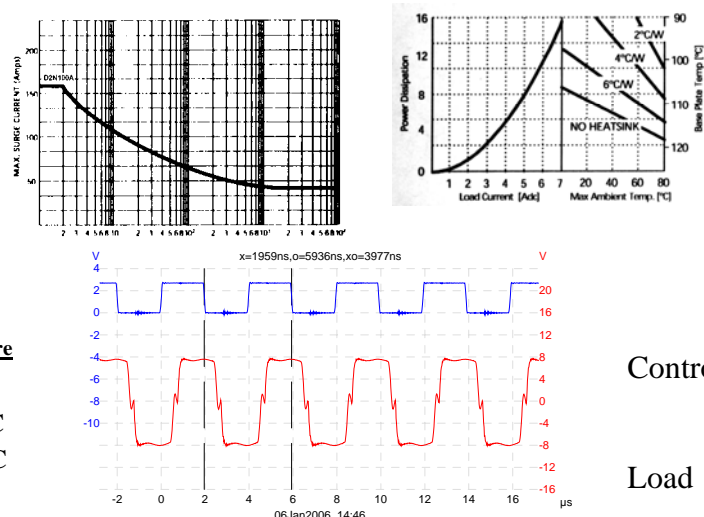

Control  
 Load

A sample of driving a load at 250 KHz

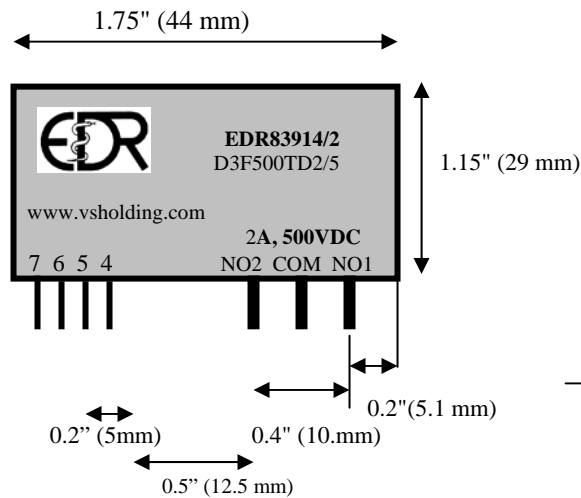

- PIN 1: NO1  
 PIN 2: COM  
 PIN 3: NO2  
 PIN 4: Control Signal (CS)  
 PIN 5: Enable (EN)  
 PIN 6: + 5VDC  
 PIN 7: GND

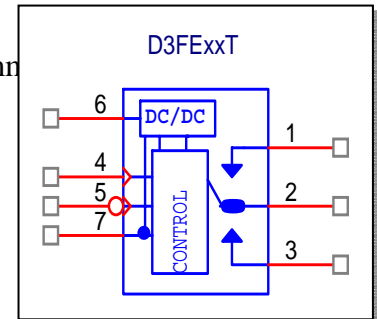

All Dimensions are in inches (millimeters).

Dimensions for SIP7 package

Terminals/solder for SIP7 package

1.15"H x 1.75"L x 0.8"W  
 control - 0.20", power - 0.6"

Transient Protection: All loads are inductive, even ones that are not so obvious or labeled. An inductive load produces a harmful transient voltage, which is much higher than the applied voltage, when it is turned on and off. A SSR built with a MOSFET output acts as an ideal switch and can produce a seemingly "non-inductive" load, which can cause damage if not suppressed. A transient voltage suppressor, which is bi-directional for AC applied voltage and unidirectional for DC applied voltage, should be used to clamp excessive spikes.

Electronic Design & Research Inc. \*\* 7331 Intermodal Dr. \*\* Louisville \*\* KY 40258

Tel: 502-933-8660; Fax: 502-933-3422; Sales: 800-336-1337; e-mail: [vsholding@vsholding.com](mailto:vsholding@vsholding.com)

**Input Electrical Characteristics (Ta = 25°C) for D3F500TD3/5, p/n EDR83914/2**

Characteristic	Test Condition	Min	Typ.	Max.	Unit
Control Voltage, low level threshold			1.7		V
Control Voltage, high level threshold			3.3		V
Enable (EN) threshold (pin 5)			1.0	2.0	V
Input Current			0.300		mA

**Input Electrical Characteristics (Ta = 25°C)**

Power Supply (pins 6), Vcc (200 mA maximum)	4.9	5	5.3	V
Maximum Vcc current at DC – 1.0 KHz		40		mA
Maximum Vcc Current at 275 KHz		200		mA

**Switching time test – Load – 8.3 Ohm & 2.2 A**

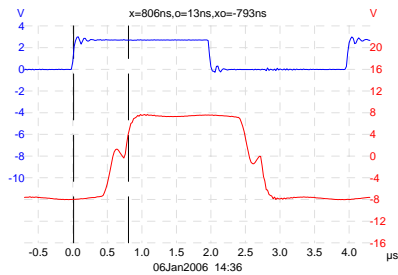

Control

Load

Figure 1 Turn-on delay is 793 nS

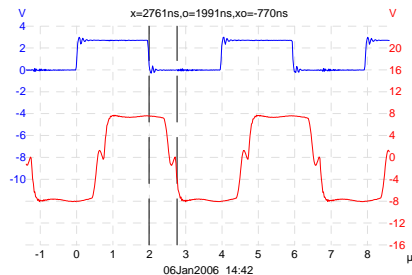

Control

Load

Figure 2 Turn-off delay is 770 nS

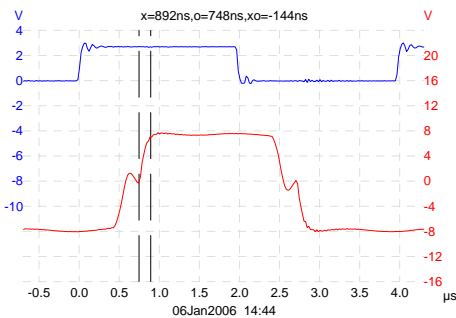

Control

Load

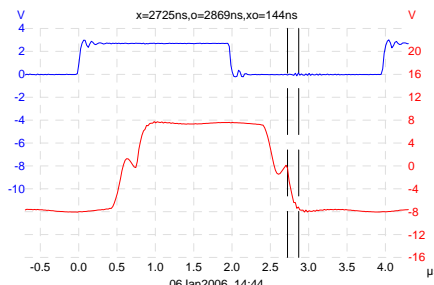

Control

Load

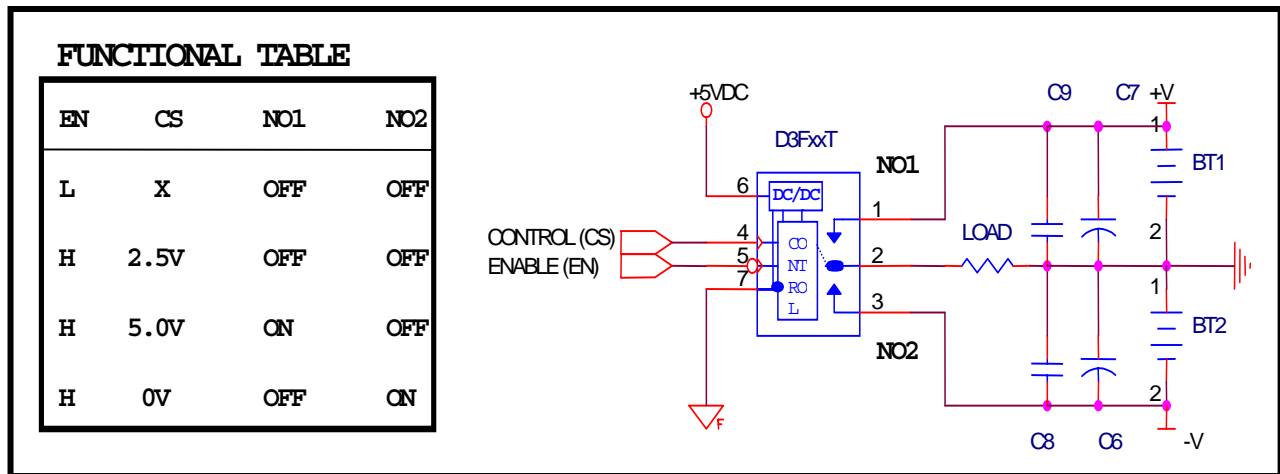

**Fig. 5 Switching Time Test Circuit**

The enable is connected to +5VDC via a 10K resistor and can be left floating.