



Electronic Design & Research
<http://www.vsholding.com>

Technology for people's ideas

NanoSeconds rise/fall time, High-Voltage push-pull switches

A switch belongs to the family of push-pull switches consists of two alternately controlled solid-state switches, which in turn are made up to a large number of high-speed MOSFETs isolated each other connected in series. The rise and fall times at the switch output are virtually the same and that allow generating an extremely precise, high-voltage, true square-wave pulses.

Applications:

- Replacement of thyratrons, ignitrons, cold cathode tubes, electron tubes, spark gaps and electromechanical high-voltage relays
- Pulsed particle accelerator/deflection
- Mass spectrometry & high energy physics
- Radar and microwave modulation
- Laser electronics and electro-optics
- Medical shock wave generators

1000V – EDR83915

Input Specifications:

Input Control Voltage (pin 4) see page #21
 Nominal Current 110 mA/5VDC
 Power Supply +Vcc (pin6) see page #21

Output Specifications:

Operating voltage range 1000 VDC
 Maximum continuous current 1.2 Arms rms
 Maximum surge current (IDM) -0.1mS 40 A
 Continuous current (ID) - Pulsed 10 A
 Maximum on-state resistance 1.10 Ohm
 Rising time 18 nS
 Delay-on time 200 nS
 Falling time 19 nS
 Pulse width range 70 nS to infinity
 Maximum switching frequency 150 KHz

All specifications were giving without any heatsink at room temperature

General Specifications:

Ambient operating temperature range -35⁰ C to 85⁰ C
 Ambient storage temperature range -55⁰ C to 125⁰ C
 Dielectric Strength input-to-output 3,000VAC

Mechanical Specifications:

Weight (oz) .2
 Encapsulation Epoxies Etc. 50-2366RFR / 50-2366CFR

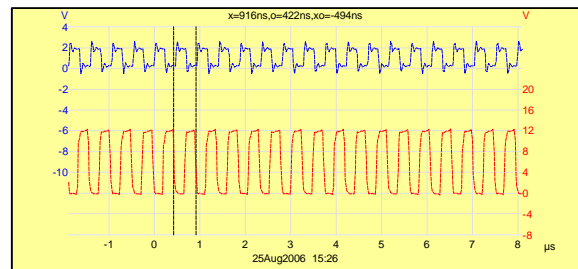
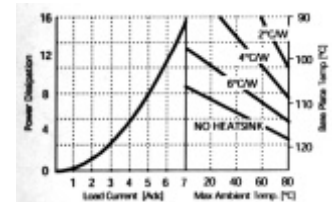
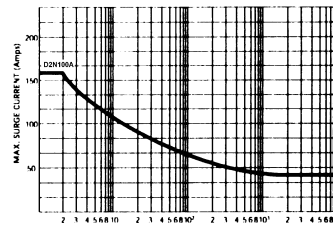

A sample of 2.00 MHz burst frequency

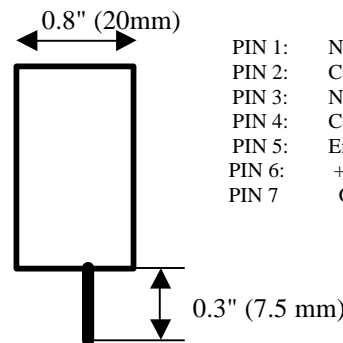
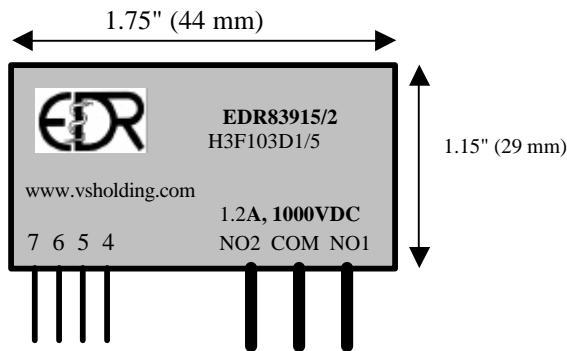

- PIN 1: NO1
- PIN 2: COM
- PIN 3: NO2
- PIN 4: Control Signal (CS)
- PIN 5: Enable (EN)
- PIN 6: + 5VDC
- PIN 7: GND

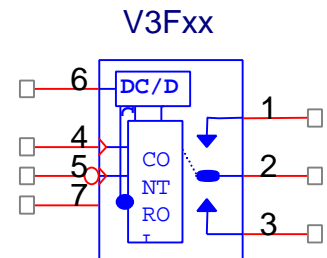

All Dimensions are in inches (millimeters).
 Dimensions for SIP7 package 1.15" H x 1.75" L x 0.8" W
 Terminals/solder for SIP7 package control - 0.20", power - 0.6"

Transient Protection: All loads are inductive, even ones that are not so obvious or labeled. An inductive load produces a harmful transient voltage, which is much higher than the applied voltage, when it is turned on and off. A SSR built with a MOSFET output acts as an ideal switch and can produce a seemingly "non-inductive" load, which can cause damage if not suppressed. A transient voltage suppressor, which is bi-directional for AC applied voltage and unidirectional for DC applied voltage, should be used to clamp excessive spikes.

Electronic Design & Research Inc. ** 7331 Intermodal Dr. ** Louisville ** KY 40258

Input Electrical Characteristics (Ta = 25°C) for V3F100TD2/5, p/n EDR83915/2

Characteristic	Test Condition	Min	Typ.	Max.	Unit
Control Voltage, low level threshold			1.7		V
Control Voltage, high level threshold			3.3		V
Enable (EN) threshold (pin 5)		1.0	3.0		V
Input Current		0.3			mA

Input Electrical Characteristics (Ta = 25°C)

Power Supply (pins 6), Vcc (200 mA maximum)	4.9	5	5.3	V
Maximum Vcc current at DC – 1.0 KHz		110		mA
Maximum Vcc Current at 150 KHz		200		mA

Switching test – +/-400V, Load – 400 Ohm & 1.0 A

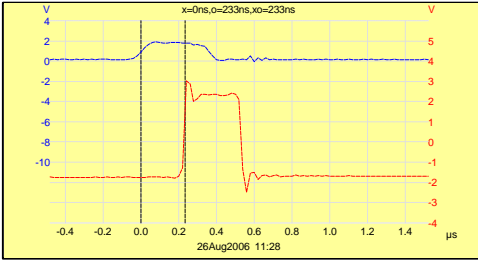

Control
Load

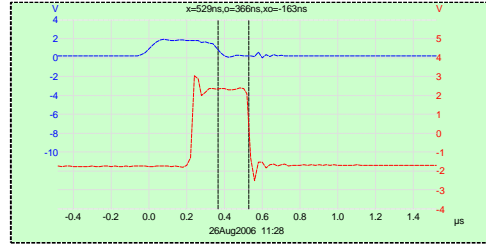

Control
Load

Figure 1 Turn-on delay is 233 ns

Figure 2 Turn-off delay is 163 ns

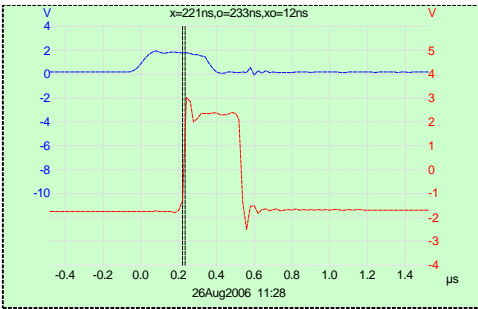

Control
Load

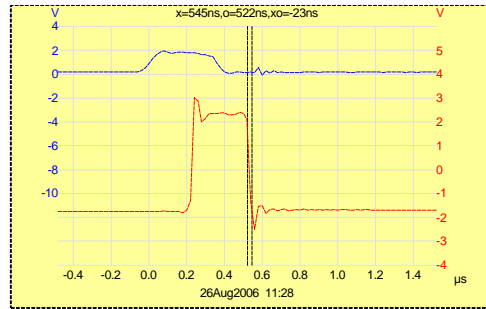

Control
Load

Figure 3 Rising time is 12ns

Figure 4 Fall time 23ns

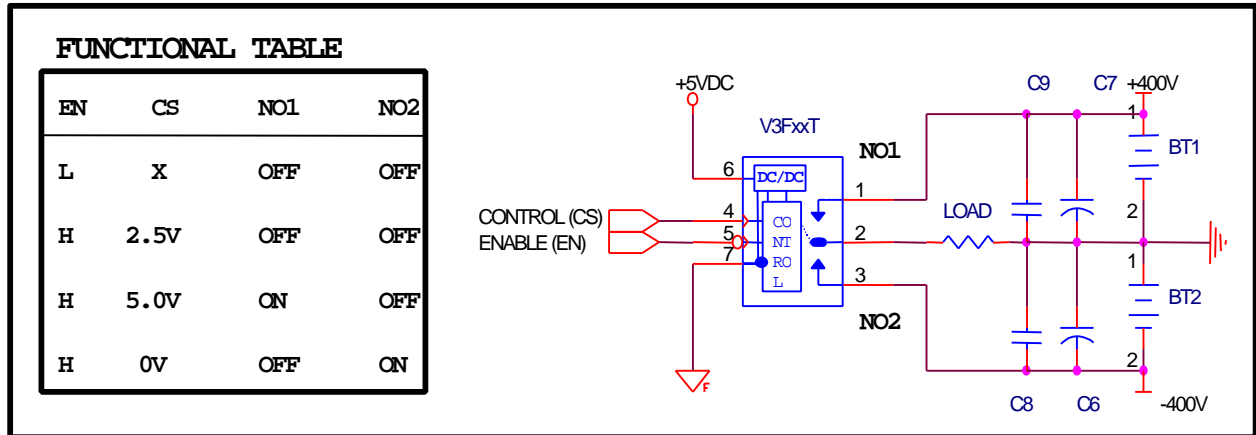

Fig. 5 Switching Time Test Circuit

A switch can be controlled via the enable (EN) input (“L”/”H”), if only + or - power needs to be applied on a load, or via the control (CS) when a bipolar power must applied onto the load.

Test Circuit for forming a fast rising/falling pulse

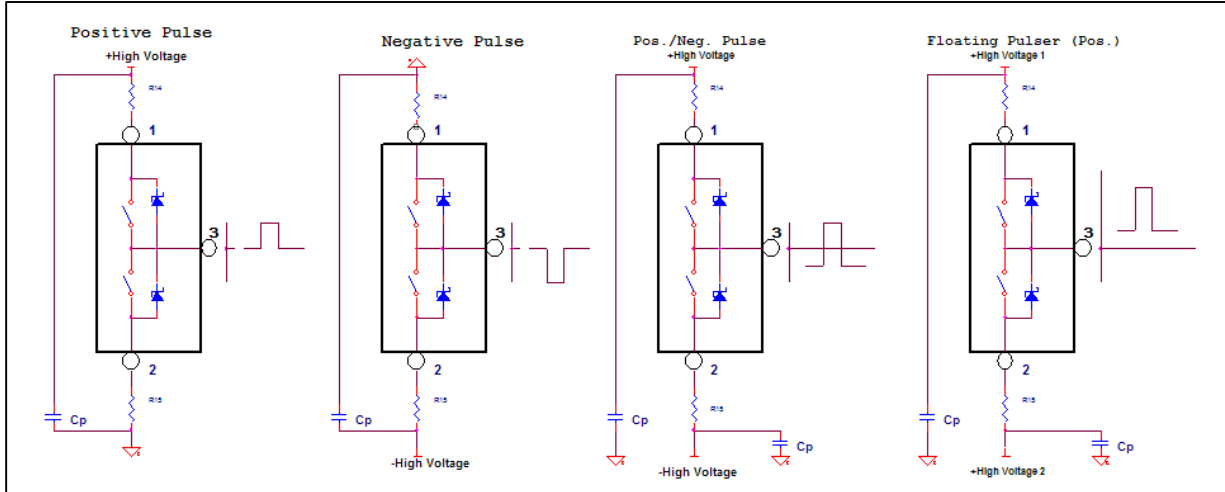

Figure 6 Basic application for generating various polarity pulses

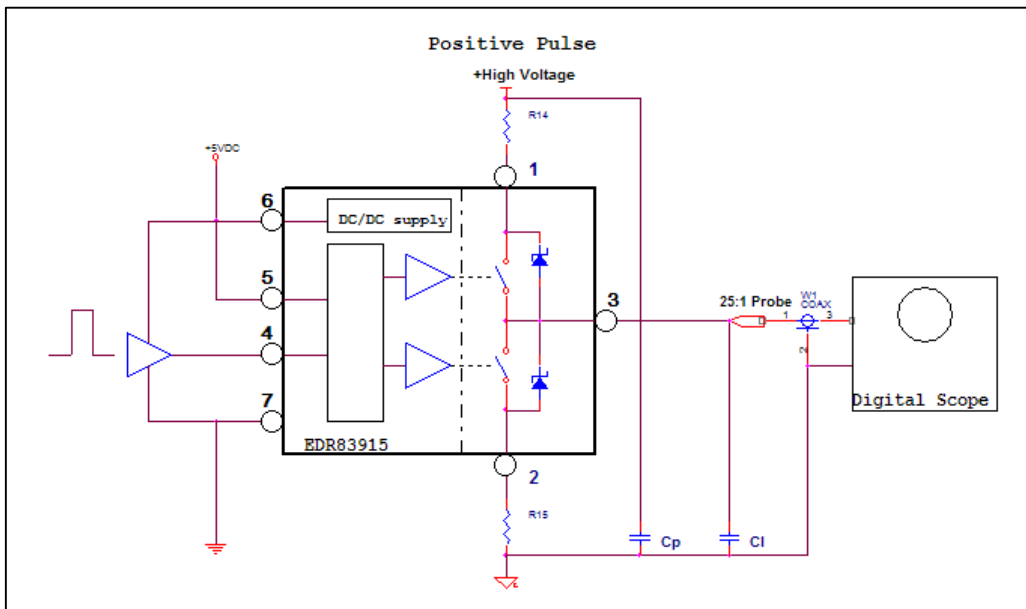

Figure 7 Test Circuit for generating a single polarity pulse

NOTES:

1. Wiring should be as short as possible
2. Capacitor C_p should be at least 50 times of C_1 for shortest transition times
3. Connected in series resistors R_{14} and R_{15} used for dumping and short protection. All measurements refer to 50 Ohm. According to a specific application, resistors can be between 0 (zero) and 1Mohm and should be selected the highest possible to avoid ringing.
4. A low impedance linkage between logic GND and earth is very important for interference free operation with a high switching speed.